

Curve ISO
Curve normali a raggio stretto
per usi generici serie ISO 3418
Normal elbows for generic uses

Raccordi Fittings

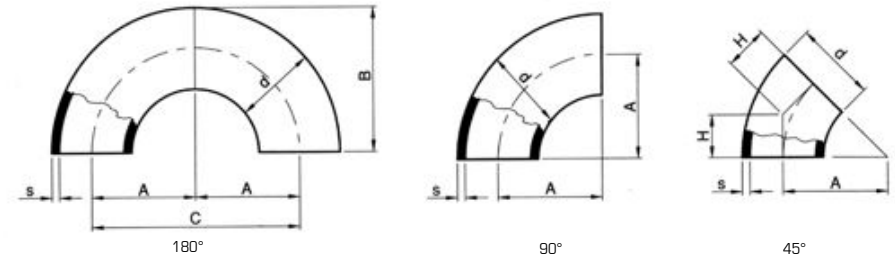

Ø esterno Ø external mm d	spessore thickness mm s	interasse wheel base mm C	DIMA 3S (R=1,5 dn)				DIMA 5S (R=2,5 dn)			
			raggio radius mm A	altezza height mm B	pesi unitari unit weight Kg		raggio radius mm A	pesi unitari unit weight Kg		
					90°	180°			90°	180°
	2		27,5	38	0,035	0,07	-	-	-	
21,3	2	55	28,5	42	0,055	0,11	115	57,5	0,13	0,26
26,9	2,3	57	33,5	48	0,085	0,17	125	62,5	0,17	0,34
30	2,3	67	38	55	0,11	0,22	145	72,5	0,23	0,46
33,7	2,6	76	45	64	0,16	0,32	165	82,5	0,29	0,58
38	2,6	90	47,5	69	0,19	0,38	185	92,5	0,37	0,74
42,4	2,6	95	51	73	0,22	0,44	195	97,5	0,41	0,82
44,5	2,6	102	57	82	0,26	0,52	215	107,5	0,49	0,98
48,3	2,6	114	68,5	95	0,36	0,72	245	122,5	0,65	1,30
54	2,9	137	72	100	0,44	0,88	255	127,5	0,77	1,54
57	2,9	144	76	106	0,50	1,00	270	135	0,87	1,74
60,3	2,9	152	92	127	0,70	1,40	320	160	1,21	2,42
70	2,9	184	95	133	0,79	1,58	350	175	1,44	2,88
76,1	3,2	190	114,5	159	1,22	2,44	410	205	2,18	4,36
88,9	3,6	229	133,5	184	1,84	3,68	475	237,5	3,25	6,50
101,6	3,6	267	142,5	196	2,09	4,18	500	250	3,68	7,36
108	3,6	285	152,5	210	2,37	4,74	540	270	4,17	8,34
114,3	4	305	181	247	3,64	7,28	625	312,5	6,25	12,50
133	4	362	190,5	260	4,04	8,08	660	330	6,94	13,88
139,7	4,5	381	216	295	5,80	11,6	750	375	10,10	20,20
159	4,5	432	228,5	313	6,50	13,0	780	390	11,14	22,28
168,3	5,4	457	270	367	10,6	21,2	910	455	17,92	35,84
193,7	5,9	540	305	415	14,9	29,8	1020	510	24,85	49,70
219,1	6,3	610	340	462	19,8	39,6	1160	580	33,72	67,44
244,5	6,3	680	381	517	24,9	49,8	1300	650	42,31	84,62
273	7,1	762	457	619	39,9	79,8	1550	775	67,53	135,06
329,9	8	914	533,5	711	57,0	114	1700	850	91,57	183,14
355,6	8	1067	533,5	717	59,5	119	1760	880	98,18	196,36
368	8,8	1067	609,5	813	82	164	1940	970	131,47	262,94
406,4	8,8	1219	609,5	819	85	170	2000	1000	158,44	316,88
419		1219								

Curve ANSI

Curve serie americana long radius (R=1,5 dn) dimensionate secondo le norme ANSI B 16.9 American series of LR elbows according to ANSI B 16.9

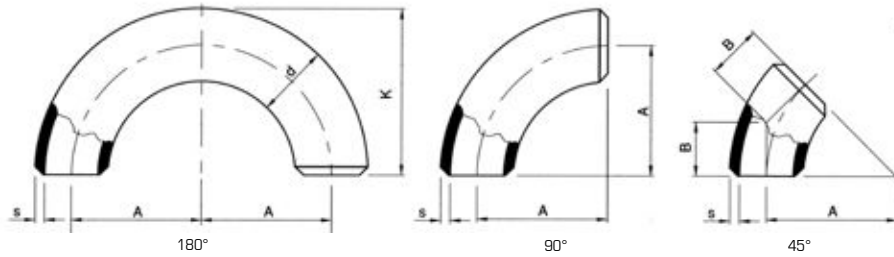

Curve ANSI

Curve serie americana short radius (R=1 dn) dimensionate secondo le norme ANSI B 16.28 American series of LR elbows according to ANSI B 16.28

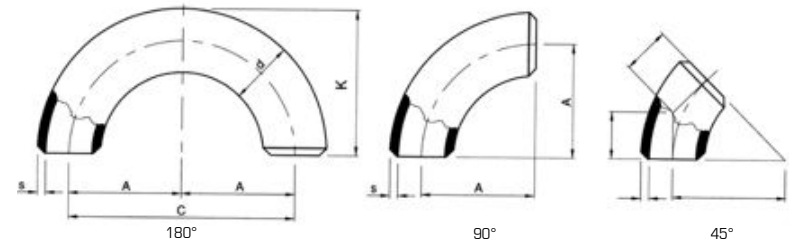

Ø in pollici inch	Ø esterno Ø external mm	interasse wheel base mm	raggio radius mm	altezza height mm	distanza distance mm	STANDARD			EXTRA STRONG			Ø in pollici inch	Ø esterno Ø external mm	interasse wheel base mm	raggio radius mm	altezza height mm	STANDARD		EXTRA STRONG						
						spessore thickness mm	pesi unitari unit weight Kg			spessore thickness mm	pesi unitari unit weight Kg						spessore thickness mm	pesi unitari unit weight Kg		spessore thickness mm	pesi unitari unit weight Kg				
							S	45°	90°		180°							S	45°		90°	180°	S	90°	180°
1/2	21,3	76,2	38	47,6	15,9	2,77	0,041	0,077	0,159	3,73	0,050	0,100	0,204	1	33,4	50,6	25	41,3	3,38	0,104	0,209	-	-	-	
3/4	26,7	57,2	38	42,9	11,1	2,87	0,041	0,077	0,159	3,91	0,50	0,104	0,209	1 1/4	42,2	63,5	32	52,4	3,56	0,180	0,350	-	-	-	
1	33,4	76,2	38	55,6	22,2	3,38	0,080	0,170	0,350	4,55	0,120	0,250	0,500	1 1/2	48,3	76,2	38	61,9	3,68	0,300	0,600	5,08	0,350	0,700	
1 1/4	42,2	95,2	48	69,8	25,4	3,56	0,120	0,250	0,500	4,85	0,170	0,350	0,700	2	60,3	101,6	51	81,0	3,91	0,500	1,00	5,54	0,650	1,30	
1 1/2	48,3	114,3	57	82,6	28,6	3,68	0,200	0,400	0,800	5,08	0,250	0,500	1,00	2 1/2	73,0	127,0	64	100,0	5,16	0,950	1,90	7,01	1,30	2,60	
2	60,3	152,4	76	106,4	34,9	3,91	0,350	0,700	1,40	5,54	0,450	0,950	1,90	3	88,9	152,4	76	120,6	5,49	1,35	2,70	7,62	1,90	3,80	
2 1/2	73,0	190,5	95	131,8	44,4	5,16	0,650	1,35	2,70	7,01	0,900	1,80	3,60	3 1/2	101,6	177,8	89	139,7	5,74	1,95	3,90	8,08	2,70	5,40	
3	88,9	228,6	114	158,8	50,8	5,49	1,10	2,20	4,40	7,62	1,45	2,90	5,80	4	114,3	203,2	102	158,8	6,02	2,70	5,40	8,56	3,60	7,20	
3 1/2	101,6	266,7	133	184,2	57,2	5,74	1,55	3,15	6,30	8,08	2,05	4,10	8,20	5	141,3	254,0	127,0	196,8	6,55	4,70	9,40	9,52	7,30	14,6	
4	114,3	304,8	152	209,6	63,5	6,02	2,05	4,10	8,20	8,56	2,75	5,50	11,0	6	168,3	304,8	152	236,5	7,11	7,30	14,6	10,97	11,0	22,0	
5	141,3	381,0	190	261,9	79,4	6,55	3,35	6,70	13,4	9,52	4,70	9,40	18,8	8	219,1	406,4	203	312,7	8,18	15,0	30,0	12,70	22,5	45,0	
6	168,3	457,2	229	312,7	95,2	7,11	5,50	11,0	22,0	10,97	8,00	16,0	32,0	10	273,0	508,0	254	390,5	9,27	26,0	52,0	12,70	34,1	68,0	
8	219,1	609,6	305	414,3	127,0	8,18	10,8	21,5	43,0	12,70	16,0	32,0	64,0	12	323,8	609,6	305	466,7	9,52	38,0	76,0	12,70	49,0	98,0	
10	273,0	762,0	381,0	517,5	158,8	9,27	18,8	39,5	79,0	12,70	25,5	51,0	102	14	355,6	711,2	356	533,4	9,52	47,6	95,3	12,70	63,0	126	
12	323,8	914,4	457	619,1	190,5	9,52	28,2	56,5	113	12,70	36,8	73,5	147	16	406,4	812,8	406	609,6	9,52	62,6	125	12,70	82,6	169	
14	355,6	1066,8	533	711,2	222,2	9,52	36,0	72,0	144	12,70	46,0	92,0	184	18	457,2	914,4	457	685,8	9,52	79,4	159	12,70	105	210	
16	406,4	1219,2	610	812,8	254,0	9,52	47,2	94,5	189	12,70	61,2	122	245	20	508,0	1016,0	508	762,0	9,52	97,5	195	12,70	130	259	
18	457,2	1371,6	686	914,4	285,8	9,52	59,9	119	239	12,70	78,9	157	315	22	558,8	1117,6	559	838,2	9,52	119	238	12,70	158	316	
20	508,0	1524,0	762,0	1016,0	315,5	9,52	73,5	147	293	12,70	97,1	194	388	24	609,6	1219,0	610	914,0	9,52	134	268	12,70	177	354	
22	558,8	1676,4	838	1117,6	342,9	9,52	88,9	178	356	12,70	118	236	472												
24	609,6	1828,8	914	1219,2	381,0	9,52	106	212	425	12,70	141	282	564												

Materiale

- Acciaio al carbonio secondo le norme ASTM A 234 grado WPB
- Acciaio legato secondo le norme ASTM A 234 grado WP 5 - 9 - 11 - 22 - 91
- Acciaio per bassa temperatura ASTM A 420 grado WPL 6

Material

- Carbon steel according to ASTM A 234 ASTM A 234 WPB
- Alloy steel according to ASTM A 234 WP 5 - 9 - 11 - 22 - 91
- Steel for low temperature according to ASTM A 420 WPL 6

Materiale

- Acciaio al carbonio secondo le norme ASTM A 234 grado WPB
- Acciaio legato secondo le norme ASTM A 234 grado WP 5 - 9 - 11 - 22 - 91
- Acciaio per bassa temperatura ASTM A 420 grado WPL 6

Material

- Carbon steel according to ASTM A 234 ASTM A 234 WPB
- Alloy steel according to ASTM A 234 WP 5 - 9 - 11 - 22 - 91
- Steel for low temperature according to ASTM A 420 WPL 6

RACCORDI A "T" - FONDELLI

Normali dimensionati secondo norme ANSI B 16.9
 Fondelli dimensionati secondo le norme ANSI B 16.9
 Normal tees according to ANSI B 16.28. Caps according to ANSI B 16.9

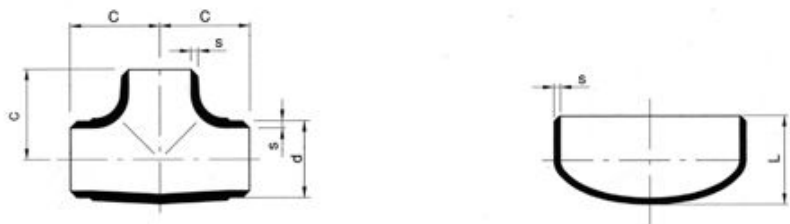

Riduzioni - Spessore standard

Reducers - standard thickness

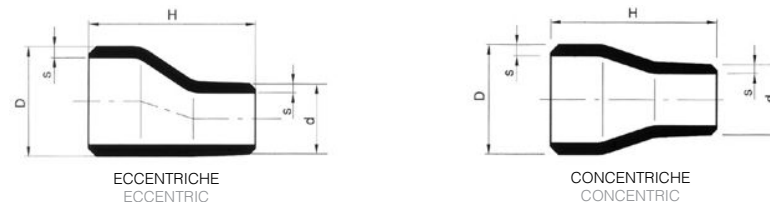

Ø in pollici inch	Ø esterno Ø external mm d	standard mm s	extra strong mm s	TE NORMALI		FONDELLI				Ø nominale nominal Ø	Ø D mm	Ø d mm	spessore thickness S mm	lunghezza length H mm	pesi unitari unit weight Kg	
				lunghezza length mm C	pesi unitari unit weight Kg STD XS	lunghezza length mm L	pesi unitari unit weight Kg STD XS	concentriche concentric	eccentriche eccentric							
1/2	21,3	2,77	3,73	25	0,12 0,14	26	0,04 0,05			1 X 3/4	33,40	26,7	3,38	51	0,19 0,19	
3/4	26,7	2,87	3,91	30	0,19 0,26	32	0,06 0,08			1 X 1/2		21,34			0,19 0,19	
1	33,4	3,38	4,55	38	0,29 0,35	38	0,10 0,13			1 X 3/8		17,14			0,19 0,19	
1 1/4	42,2	3,56	4,85	48	0,53 0,65	38	0,14 0,18			1.1/4 X 1	42,16	33,40	3,56	51	0,27 0,27	
1 1/2	48,3	3,68	5,08	57	0,77 0,96	38	0,17 0,22			1.1/4 X 3/4		26,67			0,23 0,23	
2	60,3	3,91	5,54	64	1,49 1,87	38	0,23 0,31			1.1/4 X 1/2		21,34			0,23 0,23	
2 1/2	73,0	5,16	7,01	76	2,68 3,08	38	0,37 0,47			1.1/2 X 1.1/4	48,26	42,16	3,68	64	0,33 0,44	
3	88,9	5,49	7,62	86	3,81 4,50	51	0,64 0,85			1.1/2 X 1		33,40			0,29 0,29	
3 1/2	101,6	5,74	8,08	95	5,17 6,17	64	0,97 1,31			1.1/2 X 3/4		26,67			0,25 0,34	
4	114,3	6,02	8,56	105	5,99 8,44	64	1,15 1,57			1.1/2 X 1/2		21,34			0,25 0,34	
5	141,3	6,55	9,52	124	9,93 12,9	76	1,90 2,65			2 X 1.1/2	60,32	48,26	3,91	76	0,42 0,42	
6	168,3	7,11	10,97	143	16,5 19,3	89	2,92 4,29			2 X 1.1/4		42,16			0,39 0,39	
8	219,1	8,18	12,70	178	27,7 34,5	102	5,08 7,58			2 X 1		33,40			0,35 0,35	
10	273,0	9,27	12,70	216	41,3 58,5	127	9,07 12,0			2 X 3/4		26,67			0,31 0,31	
12	323,8	9,52	12,70	254	66,7 84,8	152	13,4 17,2			2.1/2 X 2	73,02	60,32	5,16	89	0,68 0,68	
14	355,6	9,52	12,70	279	103 127	165	16,1 20,5			2.1/2 X 1.1/2		48,26			0,56 0,56	
16	406,4	9,52	12,70	305	110 167	178	20,3 26,2			2.1/2 X 1.1/4		42,16			0,56 0,56	
18	457,2	9,52	12,70	343	151 193	203	25,9 33,6			2.1/2 X 1		33,40			0,56 0,56	
20	508,0	9,52	12,70	381	229 2464	229	32,2 42,6			3 X 2.1/2	88,9	73,02	5,49	89	0,91 0,91	
22	558,8	9,52	12,70	419	252 368	254	37,6 49,9			3 X 2		60,32			0,79 0,79	
24	609,6	9,52	12,70	432	347 424	267	46,3 59,4			3 X 1.1/2		48,26			0,68 0,79	
										3 X 1.1/4		42,16			0,68 0,79	
										3 X 1		33,40			0,68 0,79	
										3.1/2 X 3	101,6	88,90	5,74	102	1,25 1,25	
										3.1/2 X 2.1/2		73,02			1,14 1,25	
										3.1/2 X 2		60,32			1,14 1,25	
										3.1/2 X 1.1/2		48,26			1,14 1,25	
										3.1/2 X 1.1/4		42,16			1,14 1,25	
										4 X 3.1/2	114,3	101,6	6,02	102	1,70 1,70	
										4 X 3		88,9			1,47 1,47	
										4 X 2.1/2		73,02			1,47 1,47	
										4 X 2		60,32			1,47 1,47	
										4 X 1.1/2		48,26			1,47 1,47	
										4 X 1.1/4		42,16			1,47 1,47	
										4 X 1		33,40			1,47 1,47	

Materiale
 - Acciaio al carbonio secondo le norma ASTM A 234 grado WPB
 - Acciaio legato secondo le norme ASTM A 234 grado WP 5 - 9 - 11 - 22 - 91
 - Acciaio per bassa temperatura ASTM A 420 grado WPL 6
 Material
 - Carbon steel according to ASTM A 234 ASTM A 234 WPB
 - Alloy steel according to ASTM A 234 WP 5 - 9 - 11 - 22 - 91
 - Steel for low temperature according to ASTM A 420 WPL 6

Riduzioni - Spessore standard Reducers - standard thickness

Ø nominale nominal Ø	Ø D mm	Ø d mm	spessore thickness S mm	lunghezza length H mm	pesi unitari unit weight Kg				
					concentriche concentric	eccentriche eccentric			
5 X 4	141,3	114,30	6,55	127	2,72	2,72			
5 X 3. 1/2		101,60			2,72	2,72			
5 X 3		88,90			2,50	2,50			
5 X 2. 1/2		73,02			2,50	2,50			
5 X 2		60,32			2,50	2,50			
6 X 5	168,3	141,30	7,11	140	3,63	3,63			
6 X 4		114,30			3,63	3,63			
6 X 3. 1/2		101,60			3,18	3,18			
6 X 3		88,90			3,18	3,18			
6 X 2.1/2		73,02			3,18	3,18			
8 X 6	219,1	168,3	8,18	152	5,90	5,90			
8 X 5		141,3			5,44	5,44			
8 X 4		114,3			4,99	4,99			
8 X 3.1/2		101,6			4,99	4,99			
8 X 3		88,9			4,99	4,99			
10 X 8	273,0	219,1	9,27	178	9,98	9,98			
10 X 6		168,3			9,98	9,98			
10 X 5		141,3			9,07	9,07			
10 X 4		114,3			9,07	9,07			
12 X 10		323,8			273,0	9,52	203	13,6	13,6
12 X 8	219,1		12,7	12,7					
12 X 6	168,3		12,7	12,7					
12 X 5	141,3		11,8	11,8					
12 X 4	114,3		11,8	11,8					
14 X 12	355,6	323,8	9,52	305	29,5	29,5			
14 X 10		273,0			29,5	29,5			
14 X 8		219,1			29,5	29,5			
14 X 6		168,3			29,5	29,5			
16 X 14		406,4			355,6	9,52	305	33,1	33,1
16 X 12	323,8		31,8	31,8					
16 X 10	273,0		31,8	31,8					
16 X 8	219,1		31,8	31,8					
18 X 16	457,2		406,4	9,52	381			38,6	38,6
18 X 14		355,6	38,6			38,6			
18 X 12		323,8	38,6			38,6			
18 X 10		273,0	38,6			38,6			
20 X 18		508,0	457,2			9,52	381	45,3	45,3
20 X 16	406,4		45,3	45,3					
20 X 14	355,6		45,3	45,3					
20 X 12	323,8		45,3	45,3					
24 X 20	609,6		508,0	9,52	457			63,5	63,5
24 X 18		457,2	63,5			63,5			
24 X 16		406,4	63,5			63,5			
26 X 24		660,4	609,6			9,52	457	68,9	68,9
26 X 20			508,0					68,9	68,9
26 X 18	457,2		68,9	68,9					
28 X 26	711,2		660,4	9,52	457			74,8	74,8
28 X 24			609,6					74,8	74,8
28 X 20		508,0	74,8			74,8			
30 X 28		762,0	711,2			9,52	457	79,8	79,8
30 X 26			660,4					79,8	79,8
30 X 24	609,6		79,8	79,8					

Riduzioni - Spessore extra strong Reducers - extra strong thickness

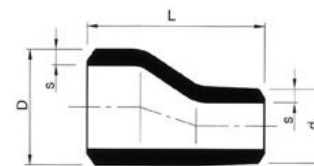

ECCENTRICHE
ECCENTRIC

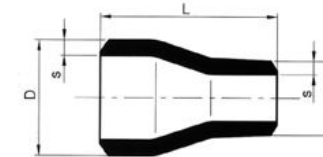

CONCENTRICHE
CONCENTRIC

Ø nominale nominal Ø	Ø D mm	Ø d mm	spessore thickness S mm	lunghezza length L mm	pesi unitari unit weight Kg	
					concentriche concentric	eccentriche eccentric
1 X 3/4	33,40	26,7	4,55	51	0,24	0,24
1 X 1/2		21,34			0,24	0,24
1 X 3/8		17,14			0,24	0,24
1.1/4 X 1	42,16	33,40	4,85	51	0,34	0,34
1.1/4 X 3/4		26,67			0,30	0,30
1.1/4 X 1/2		21,34			0,30	0,30
1.1/2 X 1.1/4	48,26	42,16	5,08	64	0,44	0,44
1.1/2 X 1		33,40			0,39	0,39
1.1/2 X 3/4		26,67			0,34	0,34
1.1/2 X 1/2		21,34			0,34	0,34
2 X 1.1/2		60,32			48,26	5,54
2 X 1. 1/4	42,16		0,53	0,53		
2 X 1	33,40		0,47	0,47		
2 X 3/4	26,67		0,43	0,43		
2.1/2 X 2	73,02		60,32	7,01	89	
2.1/2 X 1.1/2		48,26	0,79			0,79
2.1/2 X 1.1/4		42,16	0,68			0,68
2.1/2 X 1		33,40	0,68			0,79
3 X 2.1/2		88,9	73,02			7,62
3 X 2	60,32		1,02	1,02		
3 X 1.1/2	48,26		1,02	1,02		
3 X 1.1/4	42,16		1,02	1,02		
3 X 1	33,40		1,02	1,02		
3.1/2 X 3	101,6	88,90	8,08	102	1,81	1,81
3.1/2 X 2.1/2		73,02			1,81	1,81
3.1/2 X 2		60,32			1,59	1,59
3.1/2 X 1.1/2		48,26			1,59	1,59
3.1/2 X 1.1/4		42,16			1,59	1,59
4 X 3.1/2	114,3	101,6	8,56	102	2,27	2,27
4 X 3		88,9			2,27	2,27
4 X 2.1/2		73,02			2,27	2,27
4 X 2		60,32			2,04	2,04
4 X 1.1/2		48,26			2,04	2,04
4 X 1.1/4		42,16			2,04	2,04
4 X 1		33,40			2,04	2,04

Riduzioni - Spessore extra strong Reducers - extra strong thickness

Raccordi forgiati S. 3000/6000 Raccordi forgiati S. 3000/6000

Ø nominale nominal Ø	Ø D mm	Ø d mm	spessore thickness S mm	lunghezza length L mm	pesi unitari unit weight Kg				
					concentriche concentric	eccentriche eccentric			
5 X 4	141,3	114,30	9,52	127	3,06	3,06			
5 X3. 1/2		101,60			2,83	3,52			
5 X 3		88,90			2,61	3,29			
5 X 2. 1/2		73,02			2,50	3,29			
5 X 2		60,32			2,50	3,18			
6 X5	168,3	141,30	11,0	140	4,19	4,65			
6 X 4		114,30			3,74	4,99			
6 X 3. 1/2		101,60			3,52	4,99			
6 X 3		88,90			3,74	4,77			
6 X 2. 1/2		73,02			3,63	4,99			
8 X 6	219,1	168,3	12,7	152	7,82	10,1			
8 X 5		141,3			7,26	10,9			
8 X 4		114,3			7,26	11,4			
8 X 3. 1/2		101,6			6,80	11,4			
8 X 3		88,9			6,58	11,2			
10 X8	273,0	219,1	12,7	178	12,2	15,9			
10 X 6		168,3			11,8	18,6			
10 X 5		141,3			11,8	19,5			
10 X 4		114,3			10,4	20,0			
12 X 10		323,8			273,0	12,7	203	18,1	20,4
12 X 8	219,1		17,1	22,7					
12 X 6	168,3		15,9	23,1					
12 X 5	141,3		15,4	22,7					
12 X 4	114,3		15,4	22,7					
14 X 12	355,6	323,8	12,7	305	39,0	39,0			
14 X 10		273,0			39,0	39,0			
14 X 8		219,1			39,0	39,0			
14 X 6		168,3			39,0	39,0			
16 X 14		406,4			355,6	12,7	305	42,2	42,2
16 X 12	323,8		42,2	42,2					
16 X 10	273,0		42,2	42,2					
16 X 8	219,1		42,2	42,2					
18 X 16	457,2		406,4	12,7	381			52,2	52,2
18 X 14		355,6	52,2			52,2			
18 X 12		323,8	52,2			52,2			
18 X 10		273,0	52,2			52,2			
20 X 18		508,0	457,2			12,7	381	58,1	58,1
20 X 16	406,4		58,1	58,1					
20 X 14	355,6		58,1	58,1					
20 X 12	323,8		457	58,1	58,1				
24 X 20	609,6		508,0	12,7	457			81,6	81,6
24 X 18		457,2	81,6			81,6			
24 X 16		406,4	81,6			81,6			
26 X 24		660,4	609,6			12,7	457	92,1	92,1
26 X 20			508,0					92,1	92,1
26 X 18	457,2		92,1	92,1					
28 X 26	711,2		660,4	12,7	457			99,3	99,3
28 X 20			609,6					99,3	99,3
28 X 20		508,0	99,3			99,3			
30 X 28		762,0	711,2			12,7	457	107	107
30 X 26			660,4					107	107
30 X 24	609,6		107	107					



Raccordi filettati Threaded fittings

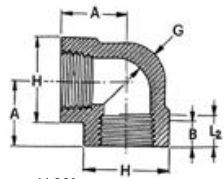

gomiti 90°
90° elbow
To ANSI B 16.11 - BS 3799

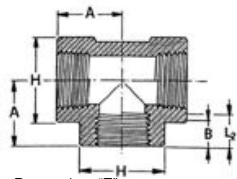

Raccordo a "T"
T
To ANSI B 16.11 - BS 3799

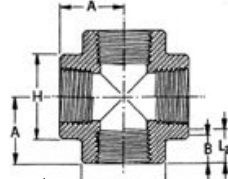

croci
cross
To ANSI B 16.11 - BS 3799

Raccordi filettati Threaded fittings

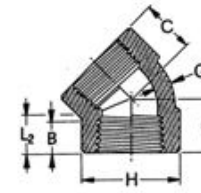

gomiti 45°
45° elbow
To ANSI B 16.11 - BS 3799

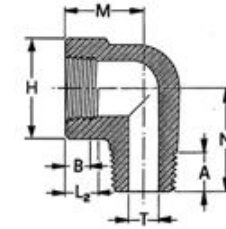

gomiti M/F
street elbow
Standard dimensions

Ø nominale
nominal pipe size

serie rating	mm	6	8	10	15	20	25	32	40	50	65	80	100
	inch	1/8	1/4	3/8	1/2	3/4	1	1 1/4	1 1/2	2	2 1/2	3	4
3000 lb	A	20.6	24.6	28.5	33.3	38.1	44.5	50.8	60.5	63.5	82.6	95.3	114.3
	H	22.4	25.4	33.3	38.1	46.0	55.6	62.0	75.4	84.1	101.6	120.6	152.4
	G	3.2	3.3	3.5	4.1	4.3	5.0	5.3	5.6	7.1	7.6	8.8	11.2
6000 lb	A	24.6	28.5	33.3	38.1	44.5	50.8	60.5	76.2	82.6	95.3	106.4	114.3
	H	25.4	33.3	38.1	46.0	55.6	62.0	75.4	84.1	101.6	120.6	146.0	152.4
	G	6.4	6.6	7.0	8.2	8.5	9.9	10.6	11.1	12.1	15.3	16.6	18.7
filetto* thread	B	6.4	8.1	9.1	10.9	12.7	14.7	17.0	17.8	19.0	23.6	25.9	27.7
	L _e	6.7	10.2	10.4	13.6	13.9	17.3	17.9	18.4	19.2	28.9	30.5	33.0

A: Distanza dalla faccia al centro
H: Diametro esterno della fascia
G: Spessore minimo di parete
B: Lunghezza minima del filetto con profilo pieno
L_e: Lunghezza minima del filetto interno utile
A: Center to end
H: Outside diameter of band
G: Minimum wall thickness
B: Minimum length of perfect thread
L_e: Minimum length of usefull thread

NOTE

Tutte le dimensioni sono in millimetri
* Le dimensioni si riferiscono a filetti ANSI B 1.20.1 NPT
Per filettature gas UNI-ISO o BS, consultare gli standards relativi
All dimensions are in millimeters
* Dimensions given refer to ANSI B 1.20.1 NPT thread
For BS or UNI-ISO threading, see relevant standard

Ø nominale
nominal pipe size

serie rating	mm	6	8	10	15	20	25	32	40	50	65	80	100
	inch	1/8	1/4	3/8	1/2	3/4	1	1 1/4	1 1/2	2	2 1/2	3	4
3000 lb	C	17.5	19.0	22.4	25.4	28.5	33.3	35.0	42.9	43.7	52.3	63.5	79.2
	H	22.4	25.4	33.3	38.1	46.0	55.6	62.0	75.4	84.1	101.6	120.6	152.4
	G	3.2	3.3	3.5	4.0	4.3	5.0	5.3	5.6	7.1	7.6	8.8	11.2
	M		24.6	28.5	33.3	38.1	44.5	50.8	60.5	63.5			
	N		26.7	32.0	35.3	40.9	50.0	61.0	69.8	82.5			
6000 lb	T		7.5	10.5	13.5	18.5	23.5	32.0	37.5	48.5			
	C	19.0	22.4	25.4	28.5	33.3	35.0	42.9	47.3	52.3	63.5	79.2	79.2
	H	25.4	33.3	38.1	46.0	55.6	62.0	75.4	84.1	101.6	120.6	146.0	152.4
	G	6.4	6.6	7.0	8.2	8.5	9.9	10.6	11.1	12.1	15.3	16.6	18.7
	M		28.5	33.3	38.1	44.5	50.8	60.5	63.5				
filetto* thread	N		32.0	35.3	40.9	50.0	61.0	69.8	82.5				
	T		5.5	7.5	10.5	12.5	16.5	24.0	29.5				
	A	9.6	11.2	12.7	14.2	15.7	19.0	20.6	20.6	22.3	26.9	28.4	31.7
	B	6.4	8.1	9.1	10.9	12.7	14.7	17.0	17.8	19.0	23.6	25.9	27.7
	L _e	6.7	10.2	10.4	13.6	13.9	17.3	17.9	18.4	19.2	28.9	30.5	33.0

C: Distanza dalla faccia al centro
H: Diametro esterno della fascia
G: Spessore minimo di parete
M: Distanza dalla faccia al centro
N: Lunghezza dell'estremità maschio
T: Foro di passaggio estr. maschio
A: Lunghezza minima del filetto esterno utile
B: Lunghezza minima del filetto con profilo pieno
L_e: Lunghezza minima del filetto interno utile
C: Center to end
H: Outside diameter of band
G: Minimum wall thickness
M: Center to end
N: Length of male end
T: Bore diameter
A: Minimum length of useful thread
B: Minimum length of perfect thread
L_e: Minimum length of useful thread

NOTE
Tutte le dimensioni sono in millimetri
* Le quote si riferiscono a filetti ANSI B 1.20.1 NPT
Per filettature gas UNI-ISO o BS, consultare gli standards relativi
All dimensions are in millimeters
* Dimensions given refer to ANSI B 1.20.1 NPT thread
For BS or UNI-ISO threading, see relevant standard

Raccordi filettati Threaded fittings

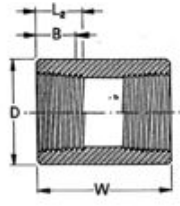

manicotti
coupling
To ANSI B 16.11 - BS 3799

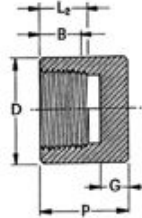

tappi femmina
cap
To ANSI B 16.11 - BS 3799

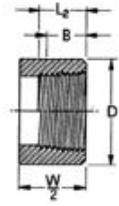

mezzi manicotti
half coupling
To ANSI B 16.11 - BS 3799

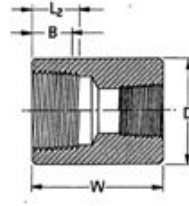

manicotti ridotti
reducing coupling
To ANSI B 16.11 - BS 3799

Raccordi filettati Threaded fittings

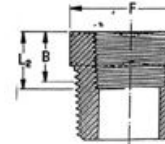

riduzioni esagonali M/F
hex head bushing
To ANSI B 16.11 - BS 3799



tappi testa esagonale
hex head plug
To ANSI B 16.11 - BS 3799

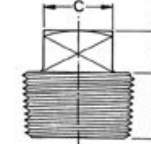

tappi testa quadra
square head plug
To ANSI B 16.11 - BS 3799

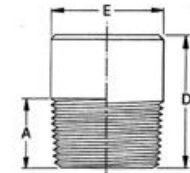

tappi testa tonda
round head plug
To ANSI B 16.11 - BS 3799

serie rating	mm inch	Ø nominale nominal pipe size											
		6 1/8	8 1/4	10 3/8	15 1/2	20 3/4	25 1	32 1 1/4	40 1 1/2	50 2	65 2 1/2	80 3	100 4
3000 lb	D	15.7	19.0	22.3	28.5	35.0	44.5	57.1	63.5	76.2	91.9	107.9	139.7
	W	31.7	35.0	38.1	47.7	50.8	60.4	66.5	79.2	85.8	91.9	107.9	120.6
	P	19.0	25.4	25.4	31.7	35.8	41.1	44.5	44.5	47.7	60.4	65.0	68.3
	G	4.8	4.8	4.8	6.3	6.3	9.6	9.6	11.2	12.7	15.7	19.0	22.3
6000 lb	D	22.3	25.4	31.7	38.1	44.5	57.1	63.5	76.2	91.9	107.9	127.0	158.7
	W	31.7	35.0	38.1	47.7	50.8	60.4	66.5	79.2	85.8	91.9	107.9	120.6
	P		26.9	26.9	33.3	38.1	42.9	46.0	47.7	50.8	63.5	68.3	74.7
	G		6.3	6.3	7.9	7.9	11.2	11.2	12.7	15.7	19.0	22.3	28.4
filetto* thread	B	6.4	8.1	9.1	10.9	12.7	14.7	17.0	17.8	19.0	23.6	25.9	27.7
	L2	6.7	10.2	10.4	13.6	13.9	17.3	17.9	18.4	19.2	28.9	30.5	33.0

serie rating	mm inch	Ø nominale nominal pipe size											
		6 1/8	8 1/4	10 3/8	15 1/2	20 3/4	25 1	32 1 1/4	40 1 1/2	50 2	65 2 1/2	80 3	100 4
3/6000 lb	A	9.6	11.2	12.7	14.2	15.7	19.0	20.6	20.6	22.3	26.9	28.4	31.7
	C	7.1	9.6	11.2	14.2	15.7	20.6	23.9	28.4	36.3	38.1	42.9	63.5
	D	35.0	41.1	41.1	44.5	44.5	50.8	50.8	50.8	63.5	69.8	69.8	76.2
	E	10.4	13.5	17.5	21.3	26.9	33.3	42	48.5	60.5	73.1	88.9	114.3
	F	11.2	15.7	17.5	22.3	26.9	35.0	44.5	50.8	63.5	76.2	88.9	117.3
	G	3.0	4.1	4.8	5.6	6.3	7.1	7.8	8.6	9.6	10.4	12.7	
filetto* thread	H	6.3	6.3	7.9	7.9	9.6	9.6	14.2	15.7	17.5	19.0	20.6	31.7
	I	6.3	6.3	7.9	9.6	11.2	12.7	14.2	15.7	17.5	19.0	20.6	25.4
	B	6.4	8.1	9.1	10.9	12.7	14.7	17.0	17.8	19.0	23.6	25.9	27.7
	L2	6.7	10.2	10.4	13.6	13.9	17.3	17.9	18.4	19.2	28.9	30.5	33.0

D: Diametro esterno
W: Lunghezza manicotto
P: Lunghezza tappo femmina
G: Spessore minimo del fondo
B: Lunghezza minima del filetto con profilo pieno
L2: Lunghezza minima del filetto interno utile
D: Outside diameter
W: End to end coupling
P: End to end cap
G: Minimum and wall thickness
B: Minimum length of perfect thread
L2: Minimum length of useful thread

NOTE
Tutte le dimensioni sono in millimetri
* Le quote si riferiscono a filetti ANSI B 1.20.1 NPT
Per filettature gas UNI-ISO o BS, consultare gli standards relativi
All dimensions are in millimeters
* Dimensions given refer to ANSI B 1.20.1 NPT thread
For BS or UNI-ISO threading, see relevant standard

A: Lunghezza minima del filetto maschio utile
C: Quadro (minimo)
D: Lunghezza minima
E: Diametro testa tonda
F: Esagono (chiave)
G: Altezza esagono minima
H: Altezza esagono minima
I: Altezza quadro minima
B: Lunghezza minima del filetto con profilo pieno
L2: Lunghezza minima del filetto interno utile
A: Minimum length of useful thread
C: Minimum width flats
D: Minimum length
E: Nominal diameter of head
F: Nominal width flats
G: Minimum hex. height
H: Minimum hex. height
I: Minimum height of square
B: Minimum length of perfect thread
L2: Minimum length of useful thread

NOTE
Tutte le dimensioni sono in millimetri
* Le quote si riferiscono a filetti ANSI B 1.20.1 NPT
Per filettature gas UNI-ISO o BS, consultare gli standards relativi
All dimensions are in millimeters
* Dimensions given refer to ANSI B 1.20.1 NPT thread
For BS or UNI-ISO threading, see relevant standard

Raccordi filettati Threaded fittings

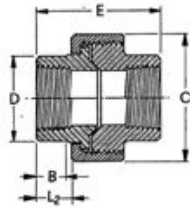

bocchettoni
union
MSS SP 83 - BS 3799

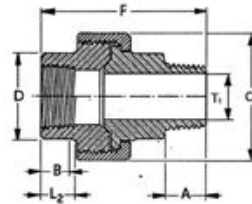

bocchettoni M/F
M/F union
MSS SP 83 - BS 3799

Raccordi filettati Threaded fittings

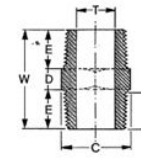

nippli esagonali
hex nipple
To BS 3799

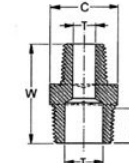

nippli esagonali ridotti
reducing hex nipple
To BS 3799

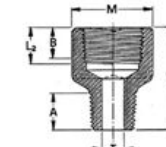

riduzioni femmina-maschio
female-male reducer
Standard dimensions

Ø nominale
nominal pipe size

serie rating	mm	6	8	10	15	20	25	32	40	50	65	80	100
	inch	1/8	1/4	3/8	1/2	3/4	1	1 1/4	1 1/2	2	2 1/2	3	4
3000 lb	C	35.0	35.0	40.0	46.0	55.5	64.5	78.0	87.0	104.0	124.0	150.0	187.0
	D	14.7	19.1	22.9	27.7	33.5	41.4	50.5	57.1	70.1	85.3	102.4	136.5
	E	41.4	41.4	46.0	49.0	56.9	62.0	71.1	76.5	86.1	118.0	109.0	153.0
	F	63.5	63.5	68.0	75.0	81.0	93.0	102.0	111.0	118.0			
	T ₁	5.0	8.0	11.0	14.0	19.0	24.0	32.0	38.0	49.0			
6000 lb	C		46.0	46.0	64.5	64.5	87.0	87.0	104.0	124.0			
	D		27.7	27.7	38.5	41.4	57.2	57.2	70.1	85.3			
	E		49.0	49.0	62.0	62.0	76.5	76.5	86.1	118.0			
	F		75.0	75.0	93.0	93.0	111.0	111.0	118.1				
	T ₁		6.0	8.0	11.0	13.0	17.0	24.5	30.0				
filetto* thread	A	9.6	11.2	12.7	14.2	15.7	19.0	2.6	26.6	22.3	26.9	28.4	31.7
	B	6.4	8.1	9.1	10.9	12.7	14.7	17.0	17.8	19.0	26.3	25.9	27.7
	L ₂	6.7	10.2	10.4	13.6	13.9	17.3	17.9	18.4	19.2	28.9	30.5	33.0

C: Dado ottagonale (chiave)
D: Estremità ottagonali (chiave) minimo
E: Lunghezza totale f/f
F: Lunghezza totale m/f
T₁: Diametro foro passaggio estrem. maschio
A: Lunghezza minima filetto esterno utile
B: Lunghezza minima del filetto con profilo pieno
L₂: Lunghezza minima del filetto interno utile
C: Width a/f union nut
D: Minimum width a/f of ends
E: End to end
F: End to end
T₁: Bore diameter of male end
A: Minimum length of useful thread
B: Minimum length of perfect thread
L₂: Minimum length of useful thread

NOTE
Tutte le dimensioni sono in millimetri
* Le quote si riferiscono a filetti ANSI B 1.20.1 NPT
Per filettature gas UNI-ISO o BS, consultare gli standard relativi
All dimensions are in millimeters
* Dimensions given refer to ANSI B 1.20.1 NPT thread
For BS or UNI-ISO threading, see relevant standard

Ø nominale
nominal pipe size

serie rating	mm	6	8	10	15	20	25	32	40	50	65	80	100
	inch	1/8	1/4	3/8	1/2	3/4	1	1 1/4	1 1/2	2	2 1/2	3	4
3000 lb	W	26.0	36.0	40.0	48.0	52.0	60.0	66.0	68.0	71.0	94.0	102.0	110.0
	E	10.0	15.0	16.0	20.0	21.0	25.0	26.0	26.0	27.0	37.0	40.0	43.0
	D	6.0	6.0	8.0	8.0	10.0	10.0	14.0	16.0	17.0	20.0	22.0	24.0
	C	11.0	15.0	18.0	22.0	27.0	35.0	45.0	50.0	62.0	76.0	93.0	119.0
	M		19.0	22.3	28.5	35.0	44.5	57.1	63.5	76.2	91.9	108.0	139.0
	T		8.0	11.0	14.0	19.0	24.0	32.0	38.0	49.0	58.2	73.0	96.0
	6000 lb	W	26.0	36.0	40.0	48.0	52.0	60.0	66.0	68.0	71.0	94.0	102.0
E		10.0	15.0	16.0	20.0	21.0	25.0	26.0	26.0	27.0	37.0	40.0	43.0
D		6.0	6.0	8.0	8.0	10.0	10.0	14.0	16.0	17.0	20.0	22.0	24.0
C		11.0	15.0	18.0	22.0	27.0	35.0	45.0	50.0	62.0	76.0	93.0	119.0
M			25.4	31.7	38.1	44.5	57.1	63.5	76.2	91.9			
T			6.0	8.0	11.0	13.0	17.0	24.5	30.0	39.0			
filetto* thread		A	9.6	11.2	12.7	14.2	15.7	19.0	20.6	26.6	22.3	26.9	28.4
	B	6.4	8.1	9.1	10.9	12.7	14.7	17.8	17.8	19.0	23.6	25.9	27.7
	L ₂	6.7	10.2	10.4	13.6	13.9	17.3	18.4	18.4	19.2	28.9	30.5	33.0

W: Lunghezza minima totale
E: Lunghezza minima dell'estremità filettata
D: Altezza minima dell'esagono
C: Esagono (chiave) minimo
T: Diametro foro
A: Lunghezza minima del filetto esterno utile
M: Esagono (chiave) o diametro esterno
B: Lunghezza minima del filetto con profilo pieno
L₂: Lunghezza minima del filetto interno utile
W: Minimum end to end
E: Minimum length of thread end
D: Minimum hexagon height
C: Minimum width nut
T: Bore diameter
A: Minimum length of useful thread
M: Width nut or outside diameter
B: Minimum length of perfect thread
L₂: Minimum length of useful thread

NOTE
Tutte le dimensioni sono in millimetri
* Le quote si riferiscono a filetti ANSI B 1.20.1 NPT
Per filettature gas UNI-ISO o BS, consultare gli standard relativi
All dimensions are in millimeters
* Dimensions given refer to ANSI B 1.20.1 NPT thread
For BS or UNI-ISO threading, see relevant standard

Raccordi filettati e a tasca da saldare

Threaded and socket welding fittings

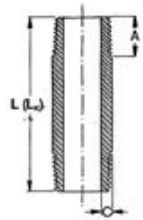

nippli tubo
pipe nipple
To ANSI B 36.10

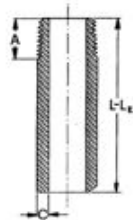

mezzi nippli
half pipe nipple
To ANSI B 36.10

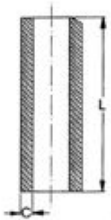

nippli tubo
pipe nipple
To ANSI B 36.10

Raccordi filettati e a tasca da saldare

Threaded and socket welding fittings

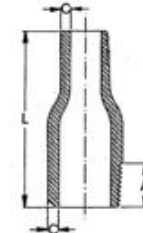

nippli tubo ridotti
swage nipple
Standard dimensions - ANSI B 36.10

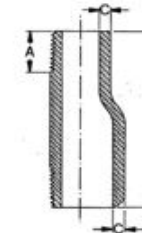

nippli tubo ridotti eccentrici
eccentric swage nipple
Standard dimensions - ANSI B 36.10

Ø nominale nominal pipe size													Ø nominale nominal pipe size														
tipo/schedula type/schedule	mm inch	6 1/8	8 1/4	10 3/8	15 1/2	20 3/4	25 1	32 1 1/4	40 1 1/2	50 2	65 2 1/2	80 3	100 4	tipo/schedula type/schedule	mm inch	6 1/8	8 1/4	10 3/8	15 1/2	20 3/4	25 1	32 1 1/4	40 1 1/2	50 2	65 2 1/2	80 3	100 4

	Ø	10.3	13.7	17.1	21.3	26.7	33.4	42.2	48.3	60.3	73.0	88.9	114.3																
STD sch.40	C	1.7	2.2	2.3	2.8	2.9	3.4	3.6	3.7	3.9	5.2	5.5	6.0																
	L																												
	Lk	20.2	23.5	26.7	29.8	33.0	33.9	43.3	43.3	46.8	57.1	60.3	68.5																
XS sch.80	C	2.4	3.0	3.2	3.7	3.9	4.6	4.8	5.1	5.5	7.0	7.6	8.6																
	L																												
	Lk	20.2	23.5	26.7	29.8	33.0	33.9	43.3	43.3	46.8	57.1	60.3	68.5																
sch.160	C				4.8	5.6	6.4	6.4	7.1	8.7	9.5	11.1	13.5																
	L																												
	Lk				29.8	33.0	33.9	43.3	43.3	46.8	57.1	60.3	68.5																
XXS	C				7.5	7.8	9.1	9.7	10.2	11.1	14.0	15.2	17.1																
	L																												
	Lk				29.8	33.0	33.9	43.3	43.3	46.8	57.1	60.3	68.5																
filetto* thread	A	9.6	11.2	12.7	14.2	15.7	19.0	20.6	20.6	22.3	26.9	28.4	31.7																

C: Spessore nominale di parete
L: Lunghezza
A: Lunghezza minima del filetto esterno utile
Lk: Lunghezza in esecuzione "close"
C: Nominal wall thickness
L: End to end
A: Minimum length of useful thread
Lk: Length in close execution

NOTE

Tutte le dimensioni sono in millimetri
* Le quote si riferiscono a filetti ANSI B 1.20.1 NPT
Per filettature gas UNI-ISO o BS, consultare gli standards relativi
All dimensions are in millimeters
* Dimensions given refer to ANSI B 1.20.1 NPT thread
For BS or UNI-ISO threading, see relevant standard

	Ø	10.3	13.7	17.1	21.3	26.7	33.4	42.2	48.3	60.3	73.0	88.9	114.3																
STD sch.40	C	1.7	2.2	2.3	2.8	2.9	3.4	3.6	3.7	3.9	5.2	5.5	6.0																
	L		69.9	69.9	69.9	76.2	88.9	101.6	114.3	165.1	178.0	203.0	228.0																
XS sch.80	C	2.4	3.0	3.2	3.7	3.9	4.6	4.8	5.1	5.5	7.0	7.6	8.6																
	L		69.9	69.9	69.9	76.2	88.9	101.6	114.3	165.1	178.0	203.0	228.0																
sch.160	C				4.8	5.6	6.4	6.4	7.1	8.7	9.5	11.1	13.5																
	L				69.9	76.2	88.9	101.6	114.3	165.1	178.0	203.0	228.0																
XXS	C				7.5	7.8	9.1	9.7	10.2	11.1	14.0	15.2	17.1																
	L				69.9	76.2	88.9	101.6	114.3	165.1	178.0	203.0	228.0																
filetto* thread	A	9.6	11.2	12.7	14.2	15.7	19.0	20.6	20.6	22.3	26.9	28.4	31.7																

C: Spessore nominale di parete
L: Lunghezza totale
A: Lunghezza minima del filetto esterno utile
C: Nominal wall thickness
L: End to end
A: Minimum length of useful thread

NOTE

Tutte le dimensioni sono in millimetri
* Le quote si riferiscono a filetti ANSI B 1.20.1 NPT
Per filettature gas UNI-ISO o BS, consultare gli standards relativi
All dimensions are in millimeters
* Dimensions given refer to ANSI B 1.20.1 NPT thread
For BS or UNI-ISO threading, see relevant standard

Raccordi a tasca da saldare Socket-welding fittings

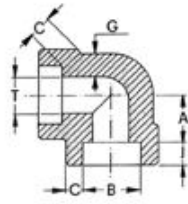

gomiti 90°
90° elbow
To ANSI B 16.11 - BS 3799

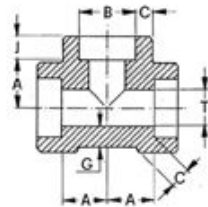

Raccordo a "T"
T
To ANSI B 16.11 - BS 3799

Raccordi a tasca da saldare Socket-welding fittings

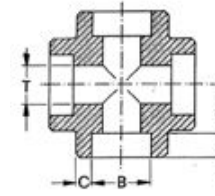

croci
cross
To ANSI B 16.11 - BS 3799

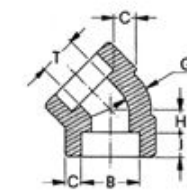

gomiti 45°
45° elbow
To ANSI B 16.11 - BS 3799

serie rating	mm inch	Ø nominale nominal pipe size											
		6 1/8	8 1/4	10 3/8	15 1/2	20 3/4	25 1	32 1 1/4	40 1 1/2	50 2	65 2 1/2	80 3	100 4
3000 lb	A	MAX 11.9	11.9	15.0	17.2	17.2	24.4	28.9	33.8	40.1	43.7	59.7	69.1
		MIN 10.4	10.4	12.0	14.2	14.2	20.3	24.9	29.7	36.1	38.6	54.6	64.0
	C	AVE 3.2	3.8	4.0	4.7	4.9	5.7	6.1	6.4	6.9	9.6	9.5	10.7
		MIN 3.2	3.3	3.5	4.1	4.3	5.0	5.3	5.5	6.0	7.7	8.3	9.3
	G	MIN 2.4	3.0	3.2	3.7	3.9	4.5	4.9	5.1	5.5	7.0	7.6	8.6
	T	MAX 7.6	10.0	13.3	16.6	21.7	27.4	35.8	41.6	53.3	64.2	79.5	103.8
		MIN 6.1	8.5	11.8	15.0	20.2	25.9	34.3	40.1	51.7	61.2	76.4	100.7
6000 lb**	A	MAX 11.9	15.0	17.2	20.5	24.4	28.9	33.8	40.1	43.6	59.6	67.0	82.2
		MIN 10.4	12.0	14.2	17.5	20.3	24.9	29.7	36.1	38.6	54.6	61.0	76.2
	C	AVE 4.0	4.6	5.0	6.0	7.0	7.9	7.9	8.9	10.9	11.9	13.9	16.9
		MIN 3.4	4.0	4.4	5.2	6.0	6.9	6.9	7.8	9.5	10.4	12.2	14.8
	G	MIN 3.1	3.7	4.0	4.8	5.6	6.3	6.3	7.1	8.7	9.6	11.2	13.6
	T	MAX 4.8	7.1	9.9	12.5	16.3	21.5	30.2	34.7	43.6	54.8	66.3	88.0
		MIN 3.2	5.6	8.4	11.0	14.8	19.9	28.7	33.2	42.1	53.3	64.8	86.5
tasca socket	B	MAX 10.9	14.3	17.8	22.0	27.3	34.1	42.8	48.9	61.4	74.2	90.2	115.8
	J	MIN 10.7	14.1	17.5	21.7	27.0	33.8	42.5	48.6	61.1	73.8	89.8	115.4
			9.7	9.7	12.7	12.7	12.7	12.7	15.7	15.7	19.0	19.0	

A: Dal fondo tasca al centro
C: Spessore di parete della tasca
G: Spessore di parete del corpo
T: Diametro foro di passaggio
B: Diametro della tasca
J: Profondità della tasca
A: Center to bottom of socket
C: Socket wall thickness
G: Body wall
T: Bore diameter of fitting
B: Socket bore diameter
J: Depth of socket

NOTE

Tutte le dimensioni sono in millimetri

** Per le dimensioni della serie 9000 lb consultare lo standard ANSI B 16.11

All dimensions are in millimeters

** For dimensions concerning class 9000 lb SEE ANSI B 16.11 standard

serie rating	mm inch	Ø nominale nominal pipe size											
		6 1/8	8 1/4	10 3/8	15 1/2	20 3/4	25 1	32 1 1/4	40 1 1/2	50 2	65 2 1/2	80 3	100 4
3000 lb	A	MAX 11.9	11.9	15.0	17.2	17.2	24.4	28.9	33.8	40.1	43.7	59.7	69.1
		MIN 10.4	10.4	12.0	14.2	14.2	20.3	24.9	29.7	36.1	38.6	54.6	64.0
	C	AVE 3.2	3.8	4.0	4.7	4.9	5.7	6.1	6.4	6.9	9.6	9.5	10.7
		MIN 3.2	3.3	3.5	4.1	4.3	5.0	5.3	5.5	6.0	7.7	8.3	9.3
	G	MIN 2.4	3.0	3.2	3.7	3.9	4.5	4.9	5.1	5.5	7.0	7.6	8.6
	H	AVE 8.6	9.6	9.4	12.7	14.2	16.3	19.6	22.6	27.4	31.0	34.3	43.7
		MIN 7.1	7.1	6.3	9.6	11.2	12.2	15.5	18.5	23.4	25.9	29.2	38.6
	T	MAX 7.6	10.0	13.3	16.6	21.7	27.4	35.8	41.6	53.3	64.2	79.5	103.8
		MIN 6.1	8.5	11.8	15.0	20.2	25.9	34.3	40.1	51.7	61.2	76.4	100.7
6000 lb**	A	MAX 11.9	15.0	17.2	20.5	24.4	28.9	33.8	40.1	43.6	59.6	67.0	82.2
		MIN 10.4	12.0	14.2	17.5	20.3	24.9	29.7	36.1	38.6	54.6	61.0	76.2
	C	AVE 4.0	4.6	5.0	6.0	7.0	7.9	7.9	8.9	10.9	11.9	13.9	16.9
		MIN 3.4	4.0	4.4	5.2	6.0	6.9	6.9	7.8	9.5	10.4	12.2	14.8
	G	MIN 3.1	3.7	4.0	4.8	5.6	6.3	6.3	7.1	8.7	9.6	11.2	13.6
	H	AVE 8.6	8.6	12.7	14.2	15.7	19.6	22.6	27.4	30.5	33.0	36.0	40.5
		MIN 7.1	7.1	9.6	11.2	12.7	15.5	18.5	23.4	26.5	29.0	32.0	36.5
	T	MAX 4.8	7.1	9.9	12.5	16.3	21.5	30.2	34.7	43.6	54.8	66.3	88.0
		MIN 3.2	5.6	8.4	11.0	14.8	19.9	28.7	33.2	42.1	53.3	64.8	86.5
tasca socket	B	MAX 10.9	14.3	17.8	22.0	27.3	34.1	42.8	48.9	61.4	74.2	90.2	115.8
	J	MIN 10.7	14.1	17.5	21.7	27.0	33.8	42.5	48.6	61.1	73.8	89.8	115.4
			9.7	9.7	12.7	12.7	12.7	12.7	15.7	15.7	19.0	19.0	

A: Dal fondo tasca al centro
C: Spessore di parete della tasca
G: Spessore di parete del corpo
H: Dal fondo tasca al centro
T: Diametro foro di passaggio
B: Diametro della tasca
J: Profondità della tasca
A: Center to bottom of socket
C: Socket wall thickness
G: Body wall
H: Center to bottom of socket
T: Bore diameter of fitting
B: Socket bore diameter
J: Depth of socket

NOTE

Tutte le dimensioni sono in millimetri

** Per le dimensioni della serie 9000 lb consultare lo standard ANSI B 16.11

All dimensions are in millimeters

** For dimensions concerning class 9000 lb SEE ANSI B 16.11 standard

Raccordi a tasca da saldare Socket-welding fittings

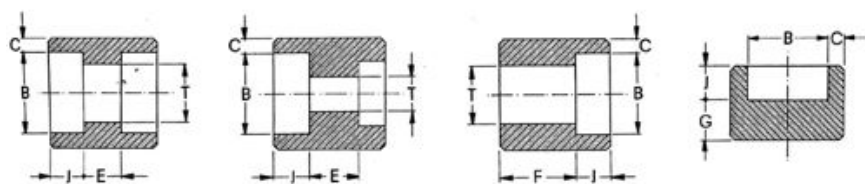

manicotti
coupling
To ANSI B 16.11 - BS 3799

manicotti ridotti
reducing coupling
To ANSI B 16.11 - BS 3799

mezzi manicotti
half coupling
To ANSI B 16.11 - BS 3799

tappi femmina
cap
To BS 3799

Raccordi a tasca da saldare Socket-welding fittings

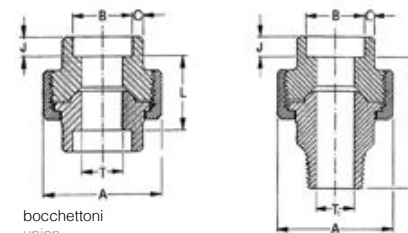

bocchettioni
union
To MSS SP 83 - BS 3799

bocchettioni M/F
M/F union
To MSS SP 83 - BS 3799

Ø nominale
nominal pipe size

serie rating	mm inch	6 1/8	8 1/4	10 3/8	15 1/2	20 3/4	25 1	32 1 1/4	40 1 1/2	50 2	65 2 1/2	80 3	100 4
3000 lb	C	AVE 3.2	3.8	4.0	4.7	4.9	5.7	6.1	6.4	6.9	8.8	9.5	10.7
		MIN 3.2	3.3	3.5	4.1	4.3	5.0	5.3	5.5	6.0	7.7	8.3	9.3
	E	MAX 7.9	7.9	8.4	12.7	12.7	16.8	16.8	16.8	23.1	24.1	24.1	24.1
		MIN 4.8	4.8	3.3	12.6	6.6	8.6	8.6	15.0	14.0	14.0	14.0	14.0
	F	MAX 16.5	16.5	19.0	23.9	25.4	30.5	32.3	33.8	43.2	45.5	47.0	50.3
		MIN 15.0	15	16.0	20.8	22.4	26.4	28.2	29.7	39.1	40.4	41.9	45.2
G	MAX 4.0	7.0	7.0	8.0	10.0	11.0	13.0	14.0	18.0	21.0	24.0	30	
	MIN 7.6	10.0	13.3	16.6	21.7	27.4	35.8	41.6	53.3	64.2	79.5	103.8	
T	MAX 6.1	8.5	11.8	15.0	20.2	25.9	34.3	40.1	51.7	61.2	76.4	100.7	
	MIN												
6000 lb**	C	AVE 3.2	3.8	4.0	4.7	4.9	5.7	6.1	6.4	6.9	8.8	9.5	10.7
		MIN 3.2	3.3	3.5	4.1	4.3	5.0	5.3	5.5	6.0	7.7	8.3	9.3
	E	MAX 7.9	7.9	8.4	12.7	12.7	16.8	16.8	16.8	23.1	24.1	24.1	24.1
		MIN 4.8	4.8	3.3	12.6	6.6	8.6	8.6	15.0	14.0	14.0	14.0	14.0
	F	MAX 16.5	16.5	19.0	23.9	25.4	30.5	32.3	33.8	43.2	45.5	47.0	50.3
		MIN 15.0	15	16.0	20.8	22.4	26.4	28.2	29.7	39.1	40.4	41.9	45.2
G	MAX 6.0	8.0	10.0	11.0	13.0	14.0	18.0	19.0	24.0	29.0	34.0	44.0	
	MIN 4.8	7.1	9.9	12.5	16.3	21.5	30.2	34.7	43.6	54.8	66.3	88.0	
T	MAX 3.2	5.6	8.4	11.0	14.8	19.9	28.7	33.2	42.1	53.3	64.8	86.5	
	MIN												
tasca socket	B	MAX 10.9	14.3	17.8	22.0	27.3	34.1	42.8	48.9	61.4	74.2	90.2	115.8
		MIN 10.7	14.1	17.5	21.7	27.0	33.8	42.5	48.6	61.1	73.8	89.8	115.4
J	MIN 9.7	9.7	9.7	9.7	12.7	12.7	12.7	12.7	15.7	15.7	15.7	19.0	

C: Spessore di parete della tasca
E: Distanza fra le tasche
F: Da fondo tasca all'estremità piana
G: Spessore del fondo
T: Diametro foro di passaggio
B: Diametro della tasca
J: Profondità della tasca
C: Socket wall thickness
E: Laying length
F: Laying length
G: End wall thickness
T: Bore diameter of fitting
B: Socket bore diameter
J: Depth of socket

NOTE

Tutte le dimensioni sono in millimetri

** Per le dimensioni della serie 9000 lb consultare lo standard ANSI B 16.11

All dimensions are in millimeters

** For dimensions concerning class 9000 lb SEE ANSI B 16.11 standard

Ø nominale
nominal pipe size

serie rating	mm inch	6 1/8	8 1/4	10 3/8	15 1/2	20 3/4	25 1	32 1 1/4	40 1 1/2	50 2	65 2 1/2	80 3	100 4
3000 lb	A	NOM 35.0	35.0	40.0	46.0	55.5	64.5	78.0	87.0	104.0	124.0	150.0	187.0
	C	AVE 3.2	3.8	4.0	4.7	4.9	5.7	6.1	6.4	6.9	8.8	9.5	10.7
		MIN 3.2	3.3	3.5	4.1	4.3	5.0	5.3	5.5	6.0	7.7	8.3	9.3
	L	MAX 22.4	22.4	26.9	26.9	31.8	34.3	40.6	42.2	45.5	61.7	63.8	97.0
		MIN 19.0	19.0	20.6	20.6	25.4	26.2	32.5	34.0	37.3	52.1	53.6	85.0
	T	MAX 6.8	9.8	13.9	17.5	21.8	28.1	35.8	41.6	52.5	64.7	77.7	102.8
		MIN 6.4	9.4	13.5	17.1	21.4	27.7	35.4	41.2	52.1	64.3	77.3	100.7
	H	NOM 54.0	54.0	57.0	62.5	67.0	77.0	84.5	93.0	96.0			
		MIN											
		MAX											
6000 lb**	A	NOM 46.0	46.0	64.5	64.5	87.0	87.0	104.0	124.0				
	C	AVE 4.6	5.0	6.0	7.0	7.9	7.9	8.9	10.9				
		MIN 4.0	4.4	5.2	6.0	6.9	6.9	7.8	9.5				
	L	MAX 31.0	31.0	38.0	35.5	46.0	43.5	52.5	81.0				
		MIN 28.5	28.5	36.0	33.0	43.0	40.0	48.0	75.0				
	T	MAX 7.1	9.9	12.5	16.3	21.5	30.2	34.7	43.6				
		MIN 5.6	8.4	11.0	14.8	18.9	28.7	33.2	42.1				
	H	NOM 65.0	64.0	70.0	69.0	95.0	93.5	100.0					
		MIN											
		MAX											
tasca socket	B	MAX 10.9	14.3	17.8	22.0	27.3	34.1	42.8	48.9	61.4	74.2	90.2	115.8
		MIN 10.7	14.1	17.5	21.7	27.0	33.8	42.5	48.6	61.1	73.8	89.8	115.4
J	MIN 9.7	9.7	9.7	9.7	12.7	12.7	12.7	12.7	15.7	15.7	15.7	19.0	

A: Dado ottagonale (chiave)
C: Spessore di parete della tasca
L: Lunghezza bocchettone F/F
T: Foro di passaggio tasca
H: Lunghezza bocchettone M/F
B: Diametro della tasca
J: Profondità della tasca
A: Width A/F union nut
C: Socket wall thickness
L: Laying length
T: Bore diameter of fitting
H: Laying length
B: Socket bore diameter
J: Depth of socket

NOTE

Tutte le dimensioni sono in millimetri

All dimensions are in millimeters

Raccordi a tasca da saldare Socket-welding fittings

Raccordi filettati e a tasca da saldare Threaded and socket-welding fittings

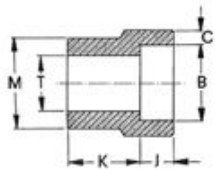

inserti di riduzione tipo 1
reducer insert - type 1
Standard dimensions

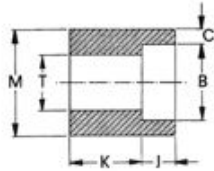

inserti di riduzione tipo 2
reducer insert - type 2
Standard dimensions

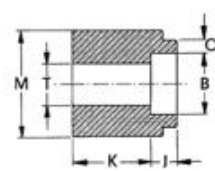

inserti di riduzione tipo 3
reducer insert - type 3
Standard dimensions

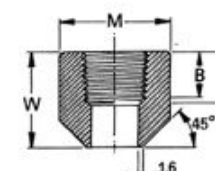

insertori
boss
Standard dimensions

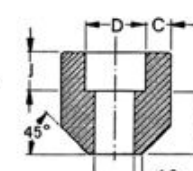

insertori
boss
Standard dimensions

serie rating	mm inch	Ø nominale nominal pipe size												serie rating	mm inch	Ø nominale nominal pipe size																											
		15 1/2	20 3/4	25 1	32 1 1/4	40 1 1/2	50 2	65 2 1/2	6	8	10	15	20			25	32	40	50	65	80	100																					
3000 lb	type	1	2	3	1	2	3	1	2	3	1	2	3	3000 lb	C AVE	3.8	4.0	4.7	4.9	5.7	6.1	6.4	6.9	6000 lb**	C AVE	4.6	5.0	6.0	7.0	7.9	7.9	8.9	10.9	filetto* tasca thread* socket	B	15.7	9.1	10.9	12.7	14.7	17.0	17.8	19.0
	K	23.9	15.7	15.7	23.9	24.6	24.6	26.2	29.5	32.5	T MAX	7.1	9.9		12.5	16.3	21.5	30.2	34.7	43.6	L2	25.4	10.4		13.9	13.9	17.3	17.9	18.4	19.2													
	M	21.6	26.9	33.6	42.4	48.5	60.9	73.6	T MIN	5.6	8.4	11.0	14.8		19.9	28.7	33.2	42.1	D MAX	14.3	17.8	22.0	27.3		34.1	42.8	48.9	61.4															
	C MIN	4.7	4.9	5.7	6.1	6.4	6.9	7.9	K	15.7	17.5	22.3	23.9		28.5	30.2	31.8	41.1	D MIN	14.1	17.5	21.7	27.0		33.8	42.5	48.6	61.1															
	C MAX	4.1	4.3	5.0	5.3	5.5	6.0	6.9	W	25.4	28.0	35.0	38.1		43.0	45.0	46.0	55.0	J MIN	9.7	9.7	9.7	12.7		12.7	12.7	15.7																
	T MAX	16.6	21.7	27.4	35.8	41.6	53.3	60.9	M	22.0	26.2	32.0	38.1		45.0	57.0	65.0	76.0																									
	T MIN	15.0	20.2	25.9	34.3	40.1	51.7	60.9																																			
	6000 lb	1/4	30.2	25.4	28.4	32.0	35.1	39.0	38.9	46.5	tasca socket	B MAX	22.0		27.3	34.1	42.8	48.9	61.4	NOTE	Tutte le dimensioni sono in millimetri Le quote K e M si riferiscono alla dimensione maggiore. Le altre a quella ridotta. All dimensions are in millimeters Dimensions K and M refer to larger size. Other dimension to the reduced size.																						
		3/8	30.2	25.4	28.4	32.5	35.1	39.0	38.9	46.5		J MIN	9.7		12.7	12.7																											
		1/2	33.3	40.1	42.2	43.2	49.0	51.0	46.0	54.1																																	
3/4		42.2	43.2	49.0	51.0	46.0	54.1																																				
1		49.0	51.0	46.0	54.1																																						
1 1/4		51.0	46.0	54.1																																							
1 1/2		46.0	54.1																																								
2		54.1																																									
M		21.6	26.9	33.6	42.4	48.5	60.9	73.6																																			
C AVE		6.0	7.0	7.9	7.9	8.9	10.9	10.9																																			
C MIN	5.2	6.0	6.9	6.9	7.8	9.5	9.5																																				
T MAX	12.5	16.3	21.5	30.2	34.7	43.6	42.1																																				
T MIN	11.0	14.8	19.9	28.7	33.2	42.1																																					

K: Dal fondo tasca all'estremità spina
M: Diametro esterno
C: Spessore di parete della tasca
T: Foro di passaggio
B: Diametro della tasca
J: Profondità della tasca

K: Laying length
M: Outside diameter
C: Socket wall thickness
T: Bore diameter of fitting
B: Socket bore diameter
J: Depth of socket

NOTE
Tutte le dimensioni sono in millimetri
Le quote K e M si riferiscono alla dimensione maggiore. Le altre a quella ridotta.
All dimensions are in millimeters
Dimensions K and M refer to larger size. Other dimension to the reduced size.

type	3000lb		3000lb	
	1/4	3/8	1/4	3/8
C AVE	3.8	4.0	4.6	5.0
C MIN	3.3	3.5	4.0	4.4
T MAX	10.0	13.3	7.1	9.9
T MIN	8.5	11.8	5.6	8.4
B MAX	14.3	17.8	14.3	17.8
B MIN	14.1	17.5	14.1	17.5
J MIN	9.7	9.7	9.7	9.7

C: Spessore di parete della tasca
T: Foro di passaggio
K: Da fondo tasca ad estr. smussata
W: Lunghezza totale
M: Diametro esterno
B: Lunghezza minima del filetto con profilo pieno
L2: Lunghezza minima del filetto interno utile
D: Diametro della tasca
J: Profondità della tasca

C: Socket wall thickness
T: Bore diameter of fitting
K: Laying length
W: End to end
M: Outside diameter
B: Minimum length of perfect thread
L2: Minimum length of useful thread
D: Socket bore diameter
J: Depth of socket

NOTE
Tutte le dimensioni sono in millimetri
** Per le dimensioni della serie 9000 lb consultare lo standard ANSI B 16.11
* Le quote si riferiscono a filetti ANSI B 1.20.1 NPT
Per filettature gas UNI-ISO o BS, consultare gli standards relativi
All dimensions are in millimeters
** For dimensions concerning class 9000 lb SEE ANSI B 16.11 standard
* Dimensions given refer to ANSI B 1.20.1 NPT thread
For BS or UNI-ISO threading, see relevant standard

Raccordi filettati e a tasca da saldare

Threaded and socket welding fittings

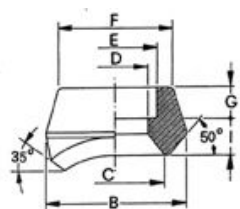

derivazioni a tasca
socket branch
Standard dimensions

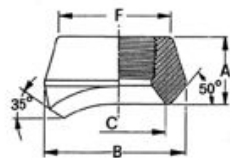

derivazioni filettate
threaded branch
Standard dimensions

Derivazioni rinforzate a saldare in testa

Reinforced butt-welding outlets

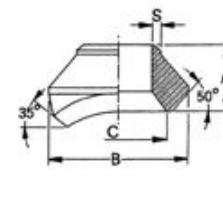

derivazioni BW STD-XS
weld branche STD-XS
Standard dimensions

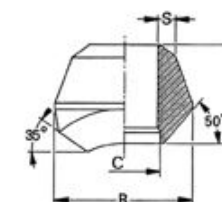

derivazioni BW 160-XXS
weld branche 160-XXS
Standard dimensions

		Ø nominale nominal pipe size											
tipo/schedula type/schedule	mm	6	8	10	15	20	25	32	40	50	65	80	100
	inch	1/8	1/4	3/8	1/2	3/4	1	1 1/4	1 1/2	2	2 1/2	3	4
3000 lb	A	17.5	17.5	20.6	25.4	27.0	33.3	33.3	34.9	38.1	46.0	50.8	57.1
	B	25.4	25.4	31.8	34.9	44.5	54.0	65.1	73.0	88.9	103.2	12.2	152.4
	C	15.9	15.9	19.0	23.8	30.2	36.5	44.5	50.8	65.1	76.2	93.7	120.6
	D	6.8	9.2	12.5	15.8	20.9	26.6	35.0	40.9	52.5	62.7	77.9	102.3
	E	10.7	14.1	17.5	21.7	27.0	33.8	42.6	48.6	61.1	73.8	89.8	115.4
	F	22.2	22.2	25.4	31.7	36.5	46.0	55.6	61.9	74.6	87.3	104.8	130.2
	G	9.5	9.5	9.5	11.1	12.7	13.5	15.1	15.1	17.5	23.8	28.6	29.4
	I	8.0	8.0	11.1	14.3	14.3	19.8	18.2	19.8	20.6	22.2	22.2	27.7
	6000 lb	A				31.7	36.5	39.7	41.3	42.8	58.7		
B					44.5	50.8	61.9	69.9	82.6	103.2			
C					19.0	25.4	33.3	38.1	49.2	58.7			
D					14.3	19.0	25.4	33.3	38.1	42.9			
E					21.7	27.0	33.8	42.6	48.6	61.1			
F					36.7	45.2	57.1	65.1	76.2	92.1			
G					9.5	14.3	15.9	20.6	20.6	22.2			
I					22.2	22.2	23.8	20.6	22.2	36.5			

A: Altezza effettiva
B: Diametro esterno
C: Diametro imbocco
D: Foro di passaggio
E: Diametro tasca
F: Diametro faccia all'estremità
G: Profondità della tasca
I: Altezza dal fondo

A: Actual height
B: Outside diameter
C: Lead-in diameter
D: Bore diameter of fitting
E: Socket bore diameter
F: Flange diameter
G: Depth of socket
I: Laying length

NOTE
Tutte le dimensioni sono in millimetri
All dimensions are in millimeters

		Ø nominale nominal pipe size											
tipo/schedula type/schedule	mm	6	8	10	15	20	25	32	40	50	65	80	100
	inch	1/8	1/4	3/8	1/2	3/4	1	1 1/4	1 1/2	2	2 1/2	3	4
Standard weight and extra strong	A	14.3	14.3	19.0	19.0	22.2	27.0	31.7	33.3	38.1	41.3	44.4	50.8
	B	25.4	25.4	31.7	34.9	44.5	54.0	65.1	73.0	88.9	103.2	122.2	152.4
	C	15.9	15.9	19.0	23.8	30.2	36.5	44.5	50.8	65.1	76.2	93.7	120.6
schedule 160 and double extra strong	A				28.6	31.7	38.1	44.5	50.8	55.6	61.9	73.0	84.1
	B				34.9	44.5	50.8	61.9	69.9	81.0	96.8	120.6	152.4
	C				14.3	19.0	25.4	33.3	38.1	42.9	54.0	73.0	98.4

A: Altezza effettiva
B: Diametro esterno
C: Diametro imbocco
S: Spessore parete della derivazione
(1): La quota S deve essere indicata in ordine
A: Actual height
B: Outside diameter
C: Lead-in diameter
S: Branch wall thickness
(1) S valve shall be indicated in order

NOTE
Tutte le dimensioni sono in millimetri
Derivazioni di diametro maggiore, fino a 24", fornite normalmente.
Altre su richiesta.
All dimensions are in millimeters
Outlets larger than 4" up to 24" are normally supplied.
Other on demand.

Derivazioni per curve e inclinate a 45° per tubi

Lateral and elbow branches

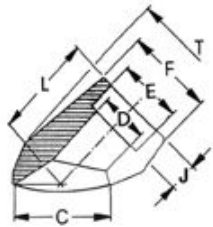

a tasca da saldare
sw end
Standard dimensions

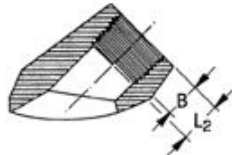

filettate
threaded end
Standard dimensions



a saldare di testa
bw end
Standard dimensions

Nippli rinforzati per derivazioni maschio

Reinforced branches for male connection



a saldare di testa
bw end
Standard dimensions

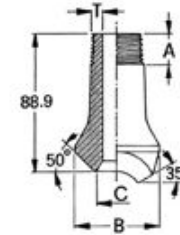

filettati
threaded
Standard dimensions



da saldare a tasca
sw end
Standard dimensions

Ø nominale
nominal pipe size

serie rating	mm inch	6 1/8	8 1/4	10 3/8	15 1/2	20 3/4	25 1	32 1 1/4	40 1 1/2	50 2	65 2 1/2	80 3	100 4
3000 lb	L		40.5	40.5	40.5	47.6	55.6	60.3	67.7	81.0			
	C		34.9	34.9	34.9	43.7	54.0	67.5	76.2	104.8			
	D ^{MAX} MIN		10.0 8.5	13.3 11.8	16.6 15.0	21.7 20.2	27.4 25.9	35.8 34.3	41.6 40.1	53.3 51.7			
	F		28.6	28.6	28.6	35.7	44.5	54.8	63.5	82.6			
	T				34.9	44.5	54.0	63.5	73.0	88.9			
6000 lb**	L		40.5	40.5	47.6	55.6	60.3	66.7	81.0				
	C		34.9	34.9	43.7	54.0	67.5	76.2	104.8				
	D ^{MAX} MIN		7.1 5.6	9.9 8.4	12.5 11.0	16.3 14.8	21.5 19.9	30.2 28.7	34.7 33.2	43.6 42.1			
	F		28.6	28.6	35.7	44.5	54.8	63.5	82.6				
	T				44.5	50.8	61.9	73.0	82.6	103.2			
filetto* tasca thread* socket	B		8.1	9.1	10.9	12.7	14.7	17.0	17.8	19.0			
	L ₂		10.2	10.4	13.6	13.9	17.3	17.9	18.4	19.2			
	E ^{MAX} MIN		14.3 14.1	17.8 17.5	22.0 21.7	27.3 27.0	34.1 33.8	42.8 42.5	49.9 48.6	61.4 61.1			
	J		9.7	9.7	9.7	12.7	12.7	12.7	12.7	15.7			

L: Lunghezza effettiva
C: Diametro imbocco
D: Foro di passaggio
F: Diametro faccia all'estremità
T: Diametro esterno
B: Lunghezza minima del filetto a profilo pieno
L₂: Lunghezza minima del filetto interno utile
E: Diametro della tasca
J: Profondità della tasca
S': Spessore parete della derivazione
(1): La quota S deve essere indicata in ordine

L: Actual length
C: Lead-in diameter
D: Bore diameter
F: Pane diameter
T: Outside diameter
B: Minimum length of perfect thread
L₂: Minimum length of useful thread
E: Socket bore diameter
J: Depth of socket
S': Branch wall thickness
(1) S valve shall be indicated in order

NOTE

Tutte le dimensioni sono in millimetri
* Le quote si riferiscono a filetti ANSI B 1.20.1 NPT
Per filettature gas UNI-ISO o BS, consultare gli standards relativi
All dimensions are in millimeters
* Dimensions given refer to ANSI B 1.20.1 NPT thread
For BS or UNI-ISO threading, see relevant standard

Ø nominale
nominal pipe size

serie/tipo/schedula rating/type/schedule	mm inch	6 1/8	8 1/4	10 3/8	15 1/2	20 3/4	25 1	32 1 1/4	40 1 1/2	50 2	65 2 1/2	80 3	100 4
3000 lb	B				34.9	44.5	54.0	65.1	73.0	88.9			
	XS				23.8	30.2	36.5	44.5	50.8	65.1			
	T				3.7	3.9	4.5	4.8	5.1	5.5			
6000 lb	B				34.9	44.5	50.8	61.9	69.9	81.0			
	160/XXS				14.9	19.0	25.4	33.3	38.1	42.9			
	T ₁₆₀ T _{XXS}				4.8	5.6	6.3	6.3	7.1	8.7			
filetto* thread*	A				14.2	15.7	19.0	20.6	20.6	22.3			

B: Diametro esterno
C: Diametro imbocco
T: Spessore di parete della derivazione
A: Lunghezza minima del filetto esterno utile
B: Outside diameter
C: Lead-in diameter
T: Branch wall thickness
A: Minimum length of useful thread

NOTE

Tutte le dimensioni sono in millimetri
* Le quote si riferiscono a filetti ANSI B 1.20.1 NPT
Per filettature gas UNI-ISO o BS, consultare gli standards relativi
All dimensions are in millimeters
* Dimensions given refer to ANSI B 1.20.1 NPT thread
For BS or UNI-ISO threading, see relevant standard

Raccordi filettati - Tabella pesi (espressi in kg.) Threaded fittings - Weights table (unit in Kg.)

Raccordi a tasca da saldare - Tabella pesi (espressi in kg.) Socket-welding fittings - Weights table (unit in Kg.)

tipo/serie type/rating	mm inch	6 1/8	8 1/4	10 3/8	15 1/2	20 3/4	25 1	32 1 1/4	40 1 1/2	50 2	65 2 1/2	80 3	100 4
gomiti 90° 90° elbow	3000 6000	0,095 0,180	0,160 0,315	0,280 0,420	0,385 0,720	0,625 1,280	1,020 1,605	1,200 2,770	2,445 3,780	2,785 6,100	5,145 9,440	7,800 17,000	14,100 14,100
gomiti 45° 45° elbow	3000 6000	0,095 0,145	0,125 0,270	0,250 0,350	0,320 0,575	0,515 1,035	0,935 1,280	0,980 2,150	1,880 2,970	2,310 4,200	3,695 7,750	5,950 14,100	10,000 10,000
T T	3000 6000	0,155 0,250	0,215 0,430	0,370 0,620	0,545 0,975	0,835 1,590	1,370 2,200	1,720 3,350	3,120 4,675	3,410 8,000	5,935 13,000	9,500 19,200	17,500 17,500
ti ridotti reducing tee	3000 6000		0,210 0,300	0,370 0,550	0,560 0,800	0,935 1,400	1,550 2,300	1,890 2,800	3,380 4,950	4,100 6,900	7,400 11,500	12,000 17,800	21,300 32,000
croci cross	2000 3000 6000		0,180 0,240 0,280	0,160 0,270 0,480	0,330 0,410 0,710	0,430 0,595 1,155	0,740 1,635 1,800	1,150 2,000 2,500	1,450 3,650 4,050	2,350 4,950 5,150	4,650 9,500 11,200	7,220 12,350 24,750	15,800 22,200 22,200
gomiti M/F street elbow	3000		0,140	0,220	0,325	0,550	0,910	1,230	1,930	2,200			
manicotti coupling	3000 6000	0,040 0,075	0,050 0,105	0,070 0,300	0,140 0,300	0,190 0,460	0,430 0,885	0,690 1,400	0,985 1,915	1,405 2,860	2,385 3,900	2,905 5,200	5,510 9,250
manicotti ridotti reducing coupling	3000 6000		0,070 0,120	0,080 0,185	0,170 0,345	0,220 0,480	0,475 1,000	0,880 1,620	1,380 2,140	2,045 3,200	2,970 4,400	4,580 5,700	8,250 10,100
mezzi manicotti half coupling	3000 6000	0,015 0,025	0,025 0,050	0,035 0,090	0,070 0,165	0,100 0,230	0,220 0,480	0,385 0,680	0,570 0,980	0,700 1,425	1,240 2,000	1,525 2,700	3,870 4,800
tappi femmina cap	3000 6000	0,025 0,045	0,045 0,095	0,060 0,045	0,115 0,240	0,175 0,385	0,380 0,755	0,610 0,920	0,845 1,365	1,165 2,140	1,905 2,900	2,775 4,100	4,960 7,500
bocchettoni union	3000 6000	0,175 0,370	0,160 0,400	0,240 0,400	0,335 0,870	0,520 1,575	0,760 2,100	1,125 1,900	1,565 3,085	2,365 6,500	5,010	7,500	15,500
bocchettoni M/F M/F union	3000		0,200	0,260	0,385	0,580	0,880	1,400	1,800	2,700			
tappi testa esag. hex h. plug	3/6000	0,015	0,030	0,045	0,075	0,130	0,230	0,450	0,585	0,980	1,800	2,540	5,095
tappi testa quadra square h. plug	3/6000	0,010	0,015	0,035	0,055	0,095	0,175	0,320	0,390	0,545	0,900	1,350	3,100
tappi testa tonda round h. plug	3/6000	0,035	0,050	0,075	0,130	0,195	0,335	0,500	0,730	1,390	2,200	3,420	6,000
nippli esagonali hex nipple	3000 6000	0,015 0,020	0,030 0,040	0,045 0,055	0,075 0,090	0,105 0,165	0,205 0,300	0,325 0,460	0,400 0,655	0,640 1,020	1,020 1,700	1,650 2,100	2,755 4,645
nippli esag. ridotti reducing hex nipple	3000 6000		0,030 0,035	0,050 0,055	0,060 0,095	0,110 0,140	0,225 0,305	0,320 0,420	0,415 0,635	0,635 0,910	1,270 1,680	2,060 2,750	3,440 4,500
riduzioni esag. M/F hex h. bushing	3/6000		0,015	0,020	0,040	0,050	0,115	0,310	0,375	0,780	0,940	1,730	4,300
riduz. F/M F/M reducer	3000 6000		0,060 0,100	0,070 0,125	0,135 0,200	0,225 0,430	0,420 0,750	0,600 1,080	0,800 1,450	1,200 2,000	2,000	2,900	5,200
nippli tubo L=100 pipe nipple L=100	STD XS 160 XSS	0,030 0,040	0,060 0,075	0,080 0,105	0,120 0,150 0,180 0,240	0,140 0,200 0,270 0,345	0,230 0,260 0,350 0,500	0,330 0,365 0,540 0,770	0,465 0,490 0,660 0,885	0,520 0,665 1,070 1,285	0,840 1,010 1,400 1,900	1,210 1,225 2,050 2,600	1,3560 2,000 3,335 4,000

tipo/serie type/rating	mm inch	6 1/8	8 1/4	10 3/8	15 1/2	20 3/4	25 1	32 1 1/4	40 1 1/2	50 2	65 2 1/2	80 3	100 4
gomiti 90° 90° elbow	3000 6000	0,100 0,100	0,095 0,160	0,130 0,290	0,245 0,415	0,320 0,680	0,470 1,150	0,765 1,380	0,980 2,680	1,640 3,215	2,395 5,850	4,525 8,400	11,500 15,500
gomiti 45° 45° elbow	3000 6000	0,090 0,095	0,085 0,120	0,100 0,230	0,095 0,035	0,255 0,540	0,395 1,000	0,650 1,120	0,800 2,070	1,190 2,705	2,100 3,750	3,400 6,300	9,150 10,500
T T	3000 6000	0,135 0,140	0,115 0,235	0,180 0,390	0,315 0,590	0,415 0,880	0,620 1,520	0,975 1,750	1,350 3,480	1,965 3,900	2,785 7,250	5,550 11,000	12,400 18,700
ti ridotti reducing tee	3000 6000		0,150 0,235	0,200 0,400	0,335 0,600	0,460 0,880	0,740 1,590	1,115 1,820	1,600 3,820	2,570 4,220	3,400 8,100	6,750 12,350	15,100 20,900
croci cross	3000 6000	0,150 0,186	0,140 0,310	0,180 0,490	0,340 0,760	0,450 1,100	0,750 2,200	1,200 2,250	1,720 4,480	2,450 5,200	3,600 9,500	7,400 14,600	16,500 24,500
manicotti coupling	3000 6000	0,040 0,050	0,055 0,075	0,070 0,100	0,125 0,170	0,185 0,245	0,275 0,420	0,385 0,490	0,460 1,405	0,925 1,900	1,325 2,550	1,550 3,000	4,200
manicotti ridotti reducing coupling	3000 6000		0,060 0,090	0,085 0,120	0,170 0,200	0,210 0,280	0,395 0,485	0,490 0,650	0,635 0,900	1,235 1,645	1,600 2,500	2,150 3,000	3,900 5,800
mezzi manicotti half coupling	3000 6000	0,050 0,060	0,060 0,085	0,085 0,150	0,145 0,210	0,205 0,300	0,325 0,485	0,460 0,620	0,575 0,815	1,040 1,635	1,605 2,200	2,125 2,650	3,850 5,000
tappi femmina cap	3000 6000	0,030 0,040	0,035 0,075	0,075 0,110	0,105 0,150	0,165 0,250	0,245 0,400	0,380 0,565	0,720 0,920	1,350 2,000	1,955 3,250	2,115 3,250	3,300 4,800
bocchettoni union	3000 6000	0,190	0,180 0,385	0,230 0,420	0,345 0,900	0,520 1,650	0,755 2,160	1,225 2,050	0,620 3,200	2,420 6,750	4,650	7,500	13,900
bocchettoni M/F M/F union	3000		0,200	0,260	0,385	0,580	0,880	1,400	1,800	2,700			
nippli tubo ridotti concentrici ed eccentrici concentric and eccentric swage nipple	STD XS 160 XSS	0,042 0,050	0,063 0,075	0,090 0,105	0,120 0,170 0,115 0,140	0,215 0,280 0,315 0,245	0,330 0,410 0,530 0,400	0,450 0,610 0,755 0,975	0,910 1,075 1,655 1,970	1,320 1,710 2,250 3,000	2,300 2,825 4,000 5,350	3,100 4,250 5,850 7,700	
inserti ridotti reducer insert	3000 6000	0,040 0,060	0,055 0,080	0,060 0,090	0,090 0,140	0,170 0,260	0,240 0,370	0,360 0,540	0,725 1,050				
insertori boss	3000 6000		0,060 0,075	0,085 0,130	0,130 0,195	0,195 0,290	0,290 0,420	0,420 0,580	0,950 1,500				
derivazioni 90° 90° branches sw & thr. end	3000 6000		0,075 0,160	0,115 0,180	0,130 0,285	0,195 0,405	0,370 0,670	0,500 0,950	0,750 1,130	0,075 3,100	1,640	2,720	4,020
derivazioni 90° a saldare di testa 90° branches bw end	STD XS 160 XSS	0,075 0,050	0,060 0,070	0,090 0,100	0,120 0,140 0,130 0,150	0,265 0,290 0,360 0,185	0,390 0,420 0,600 0,365	0,500 0,560 0,800 0,880	0,900 0,990 1,200 1,330	1,120 1,220 1,650 1,770	1,800 2,000 2,870 3,150	3,550 3,800 4,700 5,200	
derivazioni 45° e per curve 45° branches elbow banches	3000 6000		0,240 0,240	0,240 0,350	0,320 0,525	0,480 0,830	0,745 1,300	0,920 1,640	1,445 2,800	2,550 5,600			
nippli rinforzati reinforced nipples	XS 160 XSS				0,220 0,260 0,310	0,360 0,410 0,510	0,615 0,630 0,690	0,650 0,860 0,990	0,930 1,150 1,310	1,490 1,850 2,050			

Filettature di tubazioni e relativi raccordi a tenuta sul filetto

Forme di base della filettatura e nomenclatura

dimensioni della filettatura¹⁾

designazione abbreviata della filettatura	numero di passi in 25,4 mm	passo P mm	profondità del filetto h mm	diametri (di base) nel piano di misura			lunghezza di misura (distanza dal piano di misura all'estremità del tubo)				posizione piano di misura su filettatura interna		lunghezza della filettatura utile del tubo ²⁾ almeno uguale a			tolleranza di accoppiamento		
				esterno (diametro di misura)			nominale	tolleranza +e - Ti/2	massima	minima	tolleranza ³⁾ +e - Ti/2	per lunghezza nominale di misura	per lunghezza massima di misura	per lunghezza minima di misura	tolleranza di accoppiamento	numero di passi		
				medio	di nocciolo	numero di passi											numero di passi	numero di passi
d	da	d1	mm	mm	mm	mm	mm	mm	mm	mm	mm	mm	mm	mm	mm	mm		
1/8	28	0,907	0,581	9,728	9,147	8,566	4,0	0,9	1	4,9	3,1	1,1	1/4	6,5	7,4	5,6	2,5	2/34
1/4	19	1,337	0,856	13,157	12,301	11,445	6,0	1,3	1	7,3	4,7	1,7	1/4	9,7	11,0	8,4	3,7	2/34
3/8	19	1,337	0,856	16,662	15,806	14,950	6,4	1,3	1	7,7	5,1	1,7	1/4	10,1	11,4	8,8	3,7	2/34
1/2	14	1,814	1,162	20,995	19,793	18,631	8,2	1,8	1	10,0	6,4	2,3	1/4	13,2	15,0	11,4	5,0	2/34
3/4	14	1,814	1,162	26,441	25,279	24,117	9,5	1,8	1	11,3	7,7	2,3	1/4	14,5	16,3	12,7	5,0	2/34
1	11	2,309	1,479	33,249	31,770	30,291	10,4	2,3	1	12,7	8,1	2,9	1/4	16,8	19,1	14,5	6,4	2/34
1 1/4	11	2,309	1,479	41,910	40,431	38,952	12,7	2,3	1	15,0	10,4	2,9	1/4	19,1	21,4	16,8	6,4	2/34
1 1/2	11	2,309	1,479	47,803	46,324	44,845	12,7	2,3	1	15,0	10,4	2,9	1/4	19,1	21,4	16,8	6,4	2/34
2	11	2,309	1,479	59,614	58,135	56,656	15,9	2,3	1	18,2	13,6	2,9	1/4	23,4	25,7	21,1	7,5	2/34
2 1/2	11	2,309	1,479	75,184	73,705	72,226	17,5	3,5	1/2	21,0	14,0	3,5	1/2	26,7	30,2	23,2	9,2	4
3	11	2,309	1,479	87,884	86,405	84,926	20,6	3,5	1/2	24,1	17,1	3,5	1/2	29,8	33,3	26,3	9,2	4
4	11	2,309	1,479	113,030	111,551	110,072	25,4	3,5	1/2	28,9	21,9	3,5	1/2	35,8	39,3	32,3	10,4	4/12

1) Le dimensioni principali sono state convertite in millimetri sulla base di 1 in = 25,4 mm, partendo dal numero di filetti per pollice che determina il passo P, dalla formula $h = 0,640327 P$ (profondità del filetto) e dal diametro esterno nominale sul piano di misura. Se ne è dedotto il diametro medio del filetto sottraendo una volta la profondità h dal filetto dal diametro esterno nominale. L'alunghezza di misura, le tolleranze e la tolleranza di accoppiamento sono state calcolate direttamente. Le altre lunghezze figuranti nel prospetto sono state ricavate sottraendo o sommando le tolleranze o la tolleranza di accoppiamento alla lunghezza di misura. Le tolleranze e la tolleranza di accoppiamento sono espresse in millimetri ed in numero di passi.

2) La disposizione del pezzo filettato internamente deve essere tale da consentire l'avvitamento della filettatura esterna fino ad una lunghezza minima di filettatura utile data nella colonna 16. Le filettature interne passanti possono avere una lunghezza ridotta di filettatura utile non minore dell'80% dei valori della colonna 17.

3) Per i raccordi a filettatura cilindrica, calcolare le tolleranze sul diametro equivalente a quelle delle colonne 13 e 14 (1/16 delle tolleranze sulla lunghezza della colonna 13).

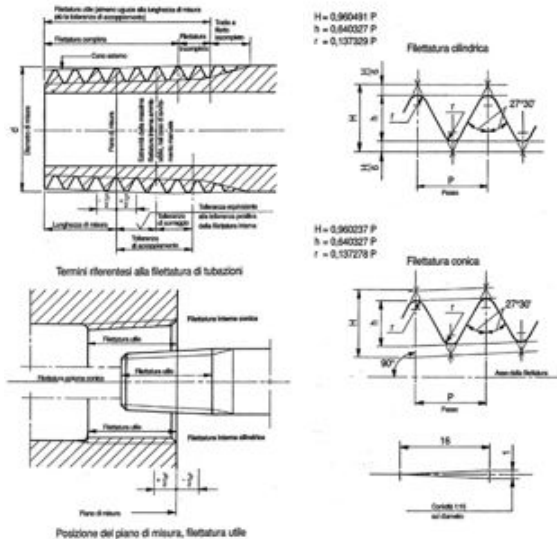

esempi di designazione completa di una filettatura 1 1/2

filettatura interna	cilindrica conica	filettature di tubazione UNI ISO 7/1-Rp 1 1/2 filettature di tubazione UNI ISO 7/1-Rc 1 1/2
filettatura esterna	sempre conica	filettature di tubazione UNI ISO 7/1-R 1 1/2

USA (american) standard taper pipe thread USA (american) standard taper pipe thread

basic dimensions of taper pipe thread¹⁾ (abbreviation of ANSI B 1.20.1)

nominal pipe size	outside diameter of pipe, D	threads per inch, n	pitch of thread, P	pitch diameter at beginning of external thread, E ₁	handtight engagement		effective thread, external			
					length ²⁾ , L ₁		length ⁴⁾ , L ₂		dia, E ₂	
					in.	thds.	in.	thds.	in.	
1/16	0.3125	27	0.03704	0.27118	0.160	4.32	0.26118	0.2611	7.05	0.28750
1/8	0.405	27	0.03704	0.36351	0.1615	4.36	0.37360	0.2639	7.12	0.38000
1/4	0.540	18	0.05556	0.47739	0.2278	4.10	0.49163	0.4018	7.23	0.50250
3/8	0.675	18	0.05556	0.61201	0.240	4.32	0.62701	0.4078	7.34	0.63750
1/2	0.840	14	0.07143	0.75843	0.320	4.48	0.77843	0.5337	7.47	0.79179
3/4	1.050	14	0.07143	0.96768	0.339	4.75	0.98887	0.5457	7.64	1.00179
1	1.315	11.5	0.08696	1.21363	0.400	4.60	1.23863	0.6828	7.85	1.25630
1 1/4	1.660	11.5	0.08696	1.55713	0.420	4.83	1.58338	0.7068	8.13	1.60130
1 1/2	1.900	11.5	0.08696	1.79609	0.420	4.83	1.82234	0.7235	8.32	1.84130
2	2.375	11.5	0.08696	2.26902	0.436	5.01	2.29627	0.7565	8.70	2.31630
2 1/2	2.875	8	0.12500	2.71953	0.682	5.46	2.76216	1.1375	9.10	2.79062
3	3.500	8	0.12500	3.34062	0.766	6.13	3.38850	1.2000	9.60	3.41562
3 1/2	4.000	8	0.12500	3.83750	0.821	6.57	3.88881	1.2500	10.00	3.91562
4	4.500	8	0.12500	4.33438	0.844	6.75	4.38712	1.3000	10.40	4.41562

nominal pipe size	wrench make-up length for external thread, L ₁ - L ₂		wrench make-up length for internal thread, length, L ₃		vanish thread, E ₃		overall length external thread, L ₄	nominal complete thread, length L ₅ , dia, E ₅		height f thread, h	increase in dia per thread, 0,0625/n	basic ⁶⁾ minor dia at small end of pipe, K ₀	
	in.	thds.	in.	thds.	in.	thds.		length L ₅	dia, E ₅				
	in.	thds.	in.	thds.	in.	thds.		in.	thds.				
1/16	0.1011	2.73	0.1111	3	0.26424	0.1285	3.47	0.3896	0.1870	0.28287	0.02963	0.00231	0.2416
1/8	0.1024	2.76	0.1111	3	0.35656	0.1285	3.47	0.3924	0.1898	0.37537	0.02963	0.00231	0.3339
1/4	0.1740	3.13	0.1667	3	0.46697	0.1928	3.47	0.5946	0.2907	0.49556	0.04444	0.00347	0.4329
3/8	0.1678	3.02	0.1667	3	0.60160	0.1928	3.47	0.6006	0.2967	0.63056	0.04444	0.00347	0.5676
1/2	0.2137	2.99	0.2143	3	0.74504	0.2478	3.47	0.7815	0.3909	0.78286	0.05714	0.00446	0.7013
3/4	0.2067	2.89	0.2143	3	0.95429	0.2478	3.47	0.7935	0.4029	0.99286	0.05714	0.00446	0.9105
1	0.2828	3.25	0.2609	3	1.19733	0.3017	3.47	0.9845	0.5089	1.24543	0.06957	0.00543	1.1441
1 1/4	0.2868	3.30	0.2609	3	1.54083	0.3017	3.47	1.0085	0.5329	1.59043	0.06957	0.00543	1.4876
1 1/2	0.3035	3.49	0.2609	3	1.77978	0.3017	3.47	1.0252	0.5496	1.83043	0.06957	0.00543	1.7265
2	0.3205	3.69	0.2609	3	2.25272	0.3017	3.47	1.0582	0.5826	2.30543	0.06957	0.00543	2.1995
2 1/2	0.4555	3.64	0.2500 ⁷⁾	2	2.70391	0.4337	3.47	1.5712	0.8875	2.77500	0.100000	0.00781	2.6195
3	0.4340	3.47	0.2500 ⁷⁾	2	3.32500	0.4337	3.47	1.6337	0.9500	3.40000	0.100000	0.00781	3.2406
3 1/2	0.4240	3.43	0.2500	2	3.82188	0.4337	3.47	1.6837	1.0000	3.90000	0.100000	0.00781	3.7375
4	0.4560	3.65	0.2500	2	4.31875	0.4337	3.47	1.7337	1.0500	4.40000	0.100000	0.00781	4.2344

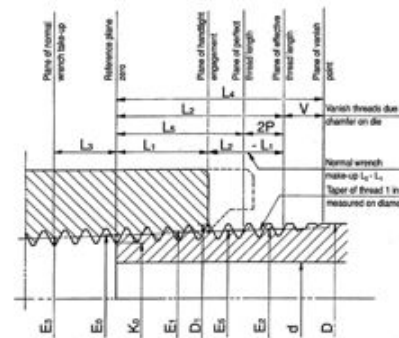

- The basic dimensions of the USA (American) standard taper pipe thread are given in inches to four or five decimal places. While this implies a greater degree of precision than is ordinarily attained, these dimensions are the basis of gage dimensions and are so expressed for the purpose of eliminating errors in computations.
- Also length of thin ring gage and length from gaging notch to small end of plug gage.
- Also pitch diameter at gaging notch (handtight plane).
- Also length of plug gage.
- The length L₅ from the end of the pipe determines the plane beyond which the thread form is incomplete at the crest. The next two threads are complete at the root. At this plane the cone formed by the crests of the thread intersects the cylinder forming the external surface of the pipe. L₅ = L₄ - 2p
- Given as information for use in selecting tap drills. (See appendix E).
- Military specification MIL-P-7105 gives the wrench make-up as three threads for 3 in. and smaller. The E₃ dimensions are as follows: size 2.5 in. 2.69809 and size 3 in. 3.31719.
- Designated, for example, as 3/8 NPT or 0.675 NPT.

Raccorderia senza saldatura acciaio inox secondo ANSI B 16.9 ASTM A 403 WP 304L/316L/321

Seamless stainless steel fittings according to
ANSI B 16.9 ASTM A 304L/316L/321

Raccorderia senza saldatura acciaio inox secondo ANSI B 16.9 ASTM A 403 WP 304L/316L/321

Seamless stainless steel fittings according to
ANSI B 16.9 ASTM A 304L/316L/321

Ø nominale nominal Ø	scheda schedule	D x a	F	peso weight	Ø nominale nominal Ø	scheda schedule	D x a	F	peso weight	Ø nominale nominal Ø	Ø		raggio radius		spessore thickness				peso weight	
											inch	mm	inch	mm	sch 10S		sch 40S		sch 10S	sch 40S
1/2	5S	21,34 x 1,65	38	0,06	14	5S	355,6 x 3,96	533	29,2	2	2.375	60,32	2	51	0,109	2,77	0,154	3,91	0,34	0,47
	10S	21,34 x 2,11	38	0,06		10S	355,6 x 4,77	533	36,2	2 1/2	2.875	73,02	2,5	64	0,120	3,05	0,23	5,16	0,56	0,94
	40S	21,34 x 2,77	38	0,08		Std	355,6 x 9,52	533	70,20	3	3.500	88,9	3	76	0,120	3,05	0,3	5,49	0,82	1,48
3/4	5S	26,67 x 1,65	38	0,05	16	5S	406,4 x 4,19	610	40,6	4	4.500	114,3	4	102	0,120	3,05	0,216	6,02	1,40	2,76
	10S	26,67 x 2,11	38	0,07		10S	406,4 x 4,77	610	47,60	6	6.625	168,3	6	152	0,134	3,4	0,237	7,11	3,45	7,19
	40S	26,67 x 2,87	38	0,09		Std	406,4 x 9,52	610	91,50	8	8.625	219,1	8	203	0,148	3,76	0,280	8,18	6,61	14,39
1	5S	33,4 x 1,65	38	0,11	18	5S	457,2 x 4,19	686	49,8	10	10.750	273,05	10	254	0,165	4,19	0,322	9,27	11,48	25,39
	10S	33,4 x 2,77	38	0,14		10S	457,2 x 4,77	686	57,30	12	12.750	323,9	12	305	0,180	4,57	0,365	9,52	17,82	37,16
	40S	33,4 x 3,38	38	0,16		Std	457,2 x 9,52	686	116	14	14.000	355,6	14	356	0,188	4,77	0,375	9,52	23,83	47,60
1 1/4	5S	42,16 x 1,65	48	0,15	20	5S	508 x 4,77	762	72	16	16.000	406,4	16	406	0,188	4,77	0,375	9,52	31,12	62,17
	10S	42,16 x 2,77	48	0,23		10S	508 x 5,54	762	83,50	18	18.000	457,2	18	457	0,188	4,77	0,375	9,52	39,38	78,69
	40S	42,16 x 3,56	48	0,25		40S	508 x 9,52	762	143,80	20	20.000	508	20	508	0,218	5,54	0,375	9,52	56,47	97,14
1 1/2	5S	48,26 x 1,65	57	0,23	24	5S	609,6 x 5,54	914	120	24	24.000	609,6	24	610	0,250	6,35	0,375	9,52	93,21	139,89
	10S	48,26 x 2,77	57	0,31		10S	609,6 x 6,35	914	138											
	40S	48,26 x 3,68	57	0,40		40S	609,6 x 9,52	914	207,80											

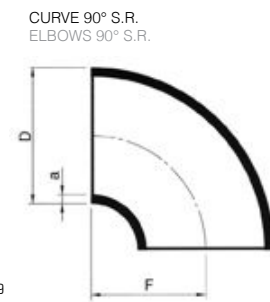

CURVE 90° S.R.
ELBOWS 90° S.R.
Le curve sono normalmente fornite anche a 180°
Elbows are normally provided also at 180°

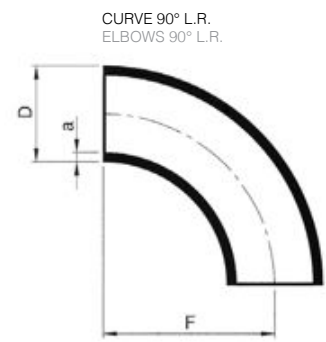

CURVE 90° L.R.
ELBOWS 90° L.R.

Possiamo fornire anche curve saldate
We are able to supply welded elbows
Le curve sono normalmente fornite anche a 45° e 180°
Elbows are normally provided also at 45° and 180°

T RIDOTTI
T RIDUCING

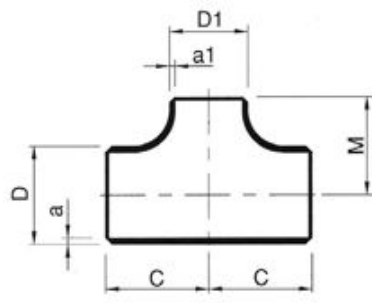

Altre dimensioni disponibili su richiesta
Other dimensions available on demand

Ø nominal o.d.	D1	D		D1		a		spessore thickness				C		M		peso weight			
		inch	mm	inch	mm	inch	mm	sch 10S		sch 40S		inch	mm	inch	mm	sch 10S	sch 40S		
2	1	2.375	60,32	1.315	33,4	0,109	2,77	0,109	2,77	0,154	3,91	0,133	3,37	2.500	63,5	2.000	50,8	0,73	1,14
2	1 1/2	2.375	60,32	1.900	48,26	0,109	2,77	0,109	2,77	0,154	3,91	0,145	3,68	2.500	63,5	2.375	60,3	0,77	1,23
3	1 1/2	3.500	88,9	1.900	48,26	0,120	3,05	0,109	2,77	0,216	5,48	0,145	3,68	3.375	85,7	2.875	73	1,61	2,98
3	2	3.500	88,9	2.375	60,32	0,120	3,05	0,109	2,77	0,216	5,48	0,154	3,91	3.375	85,7	3.000	76,2	1,63	3,01
4	2	4.500	114,3	2.375	60,32	0,120	3,05	0,109	2,77	0,237	6,02	0,154	3,91	4.125	104,8	3.500	88,9	2,54	5,09
4	3	4.500	114,3	3.500	88,9	0,120	3,05	0,120	3,05	0,237	6,02	0,216	5,49	4.125	104,8	3.875	98,4	2,61	5,28
6	3	6.625	168,3	3.500	88,9	0,134	3,4	0,120	3,05	0,280	7,11	0,216	5,49	5.625	142,9	4.875	123,8	5,76	11,94
6	4	6.625	168,3	4.500	114,3	0,134	3,4	0,134	3,05	0,280	7,11	0,237	6,02	5.625	142,9	5.125	130,2	5,86	12,12
8	4	8.625	219,1	4.500	114,3	0,148	3,76	0,134	3,05	0,322	8,17	0,237	6,02	7.000	177,8	6.125	155,6	9,81	21,29
8	6	8.625	219,1	6.625	168,3	0,148	3,76	0,148	3,4	0,322	8,17	0,280	7,11	7.000	177,8	6.625	168,3	9,91	21,65

Raccorderia senza saldatura acciaio inox secondo ANSI B 16.9 ASTM A 403 WP 304L/316L/321

Seamless stainless steel connectors according to
ANSI B 16.9 ASTM A 304L/316L/321

Raccorderia senza saldatura acciaio inox secondo ANSI B 16.9 ASTM A 403 WP 304L/316L/321

Seamless stainless steel connectors according to
ANSI B 16.9 ASTM A 304L/316L/321

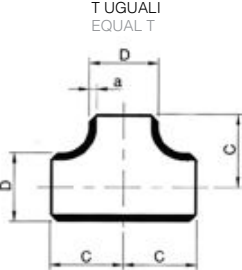
Ø nominale nominal Ø	D		spessore thickness				C		peso weight		
			sch 10S		sch 40S				sch	sch	
	inch	mm	inch	mm	inch	mm	inch	mm	10S	40S	
1/2	0.840	21,34	0.083	2,11	0.109	2,77	1.000	25,4	0,09	0,16	
3/4	1.050	26,67	0.083	2,11	0.113	2,87	1.125	28,6	0,13	0,20	
1	1.315	33,4	0.109	2,77	0.133	3,38	1.500	38,1	0,27	0,34	
1 1/4	1.660	42,16	0.109	2,77	0.140	3,56	1.875	47,6	0,50	0,59	
1 1/2	1.900	48,26	0.109	2,77	0.145	3,68	2.250	57,1	0,68	0,91	
2	2.375	60,32	0.109	2,77	0.154	3,91	2.500	63,5	0,82	1,59	
2 1/2	2.875	73,02	0.120	3,05	0.203	5,16	3.000	76,2	1,36	2,72	
3	3.500	88,9	0.120	3,05	0.216	5,49	3.375	85,7	1,77	3,18	
4	4.500	114,3	0.120	3,05	0.237	6,02	4.125	104,8	2,57	5,44	
5	5.563	141,3	0.134	3,40	0.258	6,55	4.875	123,8	5,44	14,06	
6	6.625	168,3	0.134	3,40	0.280	7,11	5.625	142,9	7,71	15,42	
8	8.625	219,1	0.148	3,76	0.322	8,18	7.000	177,8	11,34	24,95	
10	10.750	273,05	0.165	4,19	0.365	9,27	8.500	215,9	16,78	38,56	
12	12.750	323,9	0.180	4,57	0.375	9,52	10.000	254	24,49	54,43	
14	14.000	355,6	0.188	4,77	0.375	9,52	11.000	279,4	48,50	79,30	
16	16.000	406,4	0.188	4,77	0.375	9,52	12.000	304,8	58,90	99,70	
18	18.000	457,2	0.188	4,77	0.375	9,52	13.500	342,9	76,60	129,60	
20	20.000	508	0.216	5,53	0.375	9,52	15.000	381	103,30	162,20	
24	24.000	609,6	0.250	6,35	0.375	9,52	17.000	431,8	155,40	226,00	

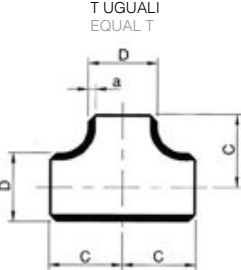

Ø nominale nominal Ø	D	D1	D		spessore thickness								H		peso weight		
					sch 10S		sch 40S		sch 10S		sch 40S				sch	sch	
			inch	mm	inch	mm	inch	mm	inch	mm	inch	mm	inch	mm	inch	mm	10S
3/4	1/2	1.050	26,67	0.840	21,34	0.083	2,11	0.083	2,11	0.113	2,87	0.109	2,77	1.500	38,1	0,10	0,13
1	1/2	1.315	33,4	0.840	21,34	0.109	2,77	0.083	2,11	0.133	3,38	0.109	2,77	2.000	50,8	0,11	0,14
1	3/4	1.315	33,4	1.050	26,67	0.109	2,77	0.083	2,11	0.133	3,38	0.113	2,87	2.000	50,8	0,11	0,14
1 1/4	1/2	1.660	42,16	0.840	21,34	0.109	2,77	0.083	2,11	0.140	3,56	0.109	2,77	2.000	50,8	0,15	0,20
1 1/4	3/4	1.660	42,16	1.050	26,67	0.109	2,77	0.083	2,11	0.140	3,56	0.113	2,87	2.000	50,8	0,15	0,20
1 1/4	1	1.660	42,16	1.315	33,4	0.109	2,77	0.109	2,77	0.145	3,56	0.133	3,38	2.000	50,8	0,16	0,20
1 1/2	1/2	1.900	48,26	0.840	21,34	0.109	2,77	0.083	2,11	0.145	3,68	0.109	2,77	2.500	63,5	0,15	0,20
1 1/2	3/4	1.900	48,26	1.050	26,67	0.109	2,77	0.083	2,11	0.145	3,68	0.113	2,87	2.500	63,5	0,16	0,22
1 1/2	1	1.900	48,26	1.315	33,4	0.109	2,77	0.109	2,77	0.145	3,68	0.133	3,38	2.500	63,5	0,18	0,26
1 1/2	1 1/4	1.900	48,26	1.660	42,16	0.109	2,77	0.109	2,11	0.145	3,68	0.140	3,56	2.500	63,5	0,20	0,26
2	3/4	2.375	60,32	1.050	26,67	0.109	2,77	0.083	2,11	0.154	3,91	0.113	2,87	3.000	76,2	0,24	0,33
2	1	2.375	60,32	1.315	33,4	0.109	2,77	0.109	2,77	0.154	3,91	0.133	3,38	3.000	76,2	0,26	0,37
2	1 1/4	2.375	60,32	1.660	42,16	0.109	2,77	0.109	2,77	0.154	3,91	0.140	3,56	3.000	76,2	0,28	0,39
2	1 1/2	2.375	60,32	1.900	48,26	0.109	2,77	0.109	2,11	0.154	3,91	0.145	3,68	3.000	76,2	0,29	0,41
2 1/2	1	2.875	73,02	1.315	33,4	0.120	3,05	0.109	2,77	0.203	5,16	0.133	3,38	3.500	88,9	0,35	0,59
2 1/2	1 1/4	2.875	73,02	1.660	42,16	0.120	3,05	0.109	2,77	0.203	5,16	0.140	3,56	3.500	88,9	0,39	0,67
2 1/2	1 1/2	2.875	73,02	1.900	48,26	0.120	3,05	0.109	2,77	0.203	5,16	0.145	3,68	3.500	88,9	0,41	0,69
2 1/2	2	2.875	73,02	2.375	60,32	0.120	3,05	0.109	2,77	0.216	5,16	0.154	3,91	3.500	88,9	0,43	0,73
3	1	3.500	88,9	1.315	33,4	0.120	3,05	0.109	2,77	0.216	5,49	0.133	3,38	3.500	88,9	0,41	0,72
3	1 1/4	3.500	88,9	1.660	42,16	0.120	3,05	0.109	2,77	0.216	5,49	0.140	3,56	3.500	88,9	0,43	0,78
3	1 1/2	3.500	88,9	1.900	48,26	0.120	3,05	0.109	2,77	0.216	5,49	0.145	3,68	3.500	88,9	0,48	0,45
3	2	3.500	88,9	2.375	60,32	0.120	3,05	0.109	2,77	0.216	5,49	0.154	3,91	3.500	88,9	0,51	0,91
3	2 1/2	3.500	88,9	2.875	73,02	0.120	3,05	0.120	3,05	0.237	5,49	0.203	5,16	3.500	88,9	0,55	0,98
4	1 1/2	4.500	114,3	1.900	48,26	0.120	3,05	0.109	2,77	0.237	6,02	0.145	3,68	4.000	101,6	0,63	1,24
4	2	4.500	114,3	2.375	60,32	0.120	3,05	0.109	2,77	0.237	6,02	0.154	3,91	4.000	101,6	0,73	1,44
4	2 1/2	4.500	114,3	2.875	73,02	0.120	3,05	0.120	3,05	0.237	6,02	0.203	5,16	4.000	101,6	0,77	1,52
4	3	4.500	114,3	3.500	88,9	0.120	3,05	0.120	3,05	0.258	6,02	0.216	5,49	4.000	101,6	0,81	1,59
5	2	5.563	141,3	2.375	60,32	0.134	3,40	0.109	2,77	0.258	6,55	0.154	3,91	5.000	127	1,19	2,75
5	2 1/2	5.563	141,3	2.875	73,02	0.134	3,40	0.120	3,05	0.258	6,55	0.203	5,15	5.000	127	1,31	2,51
5	3	5.563	141,3	3.500	88,9	0.134	3,40	0.120	3,05	0.258	6,55	0.216	5,49	5.000	127	1,36	2,61
5	4	5.563	141,3	4.500	114,3	0.134	3,40	0.120	3,05	0.258	6,55	0.237	6,02	5.000	127	1,42	2,73
6	2 1/2	6.625	168,3	2.875	73,02	0.134	3,40	0.120	3,05	0.280	7,11	0.203	5,16	5.500	139,7	1,66	3,47
6	3	6.625	168,3	3.500	88,9	0.134	3,40	0.120	3,05	0.280	7,11	0.216	5,49	5.500	139,7	1,74	3,64
6	4	6.625	168,3	4.500	114,3	0.134	3,40	0.120	3,05	0.280	7,11	0.237	6,02	5.500	139,7	1,78	3,73
6	5	6.625	168,3	5.563	141,3	0.134	3,40	0.134	3,40	0.280	7,11	0.258	6,55	5.500	139,7	1,88	3,94
8	6	8.625	219,1	6.625	168,3	0.148	3,76	0.134	3,40	0.322	8,18	0.280	7,11	6.000	152,4	2,92	6,35
10	8	10.750	273,05	8.625	219,1	0.165	4,19	0.148	3,76	0.365	9,27	0.322	8,18	7.000	177,8	4,78	10,57
12	10	12.750	323,9	10.750	273,05	0.180	4,57	0.165	4,19	0.375	9,53	0.365	9,27	8.000	203,2	7,29	15,2

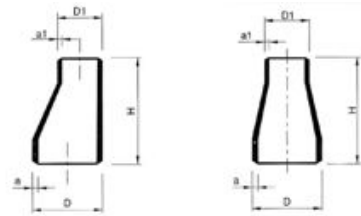

RIDUZIONI ECCENTRICHE E CONCENTRICHE
ECCENTRIC AND CONCENTRIC REDUCERS

Altre dimensioni disponibili su richiesta
Other dimensions available on demand

FONDELLI CAPS	Ø nominal o.d.	D		spessore thickness				C		peso weight	
		inch	mm	sch 10S		sch 40S		inch	mm	sch	sch
		inch	mm	inch	mm	inch	mm	inch	mm	10S	40S
	1/2	0.840	21,34	0.083	2,11	0.019	2,77	1.000	25,4	0,03	0,03
	3/4	1.050	26,67	0.083	2,11	0.113	2,87	1.000	25,4	0,05	0,06
	1	1.315	33,4	0.109	2,77	0.133	3,38	1.500	38,1	0,07	0,09
	1 1/4	1.660	42,16	0.109	2,77	0.140	3,56	1.500	38,1	0,10	0,13
	1 1/2	1.900	48,26	0.109	2,77	0.145	3,68	1.500	38,1	0,13	0,17
	2	2.375	60,32	0.109	2,77	0.154	3,91	1.500	38,1	0,18	0,26
	2 1/2	2.875	73,02	0.120	3,05	0.203	5,16	1.500	38,1	0,24	0,41
	3	3.500	88,9	0.120	3,05	0.216	5,49	2.000	50,8	0,37	0,68
	4	4.500	114,3	0.120	3,05	0.237	6,02	2.500	63,5	0,57	1,13
	5	5.563	141,3	0.134	3,40	0.258	6,55	3.000	76,2	1,09	2,10
	6	6.625	168,3	0.134	3,40	0.280	7,11	3.500	88,9	1,40	2,93
	8	8.625	219,1	0.148	3,76	0.322	8,18	4.000	101,6	2,46	5,34
	10	10.750	273,05	0.165	4,19	0.365	9,27	5.000	127	4,48	9,90
	12	12.750	323,9	0.180	4,57	0.375	9,53	6.000	152,4	6,62	13,80